

VOLUME 14 NO. 3
May-June 1951

Journal of

MILK and FOOD TECHNOLOGY

Official Publication

International Association of Milk and Food Sanitarians, Inc.

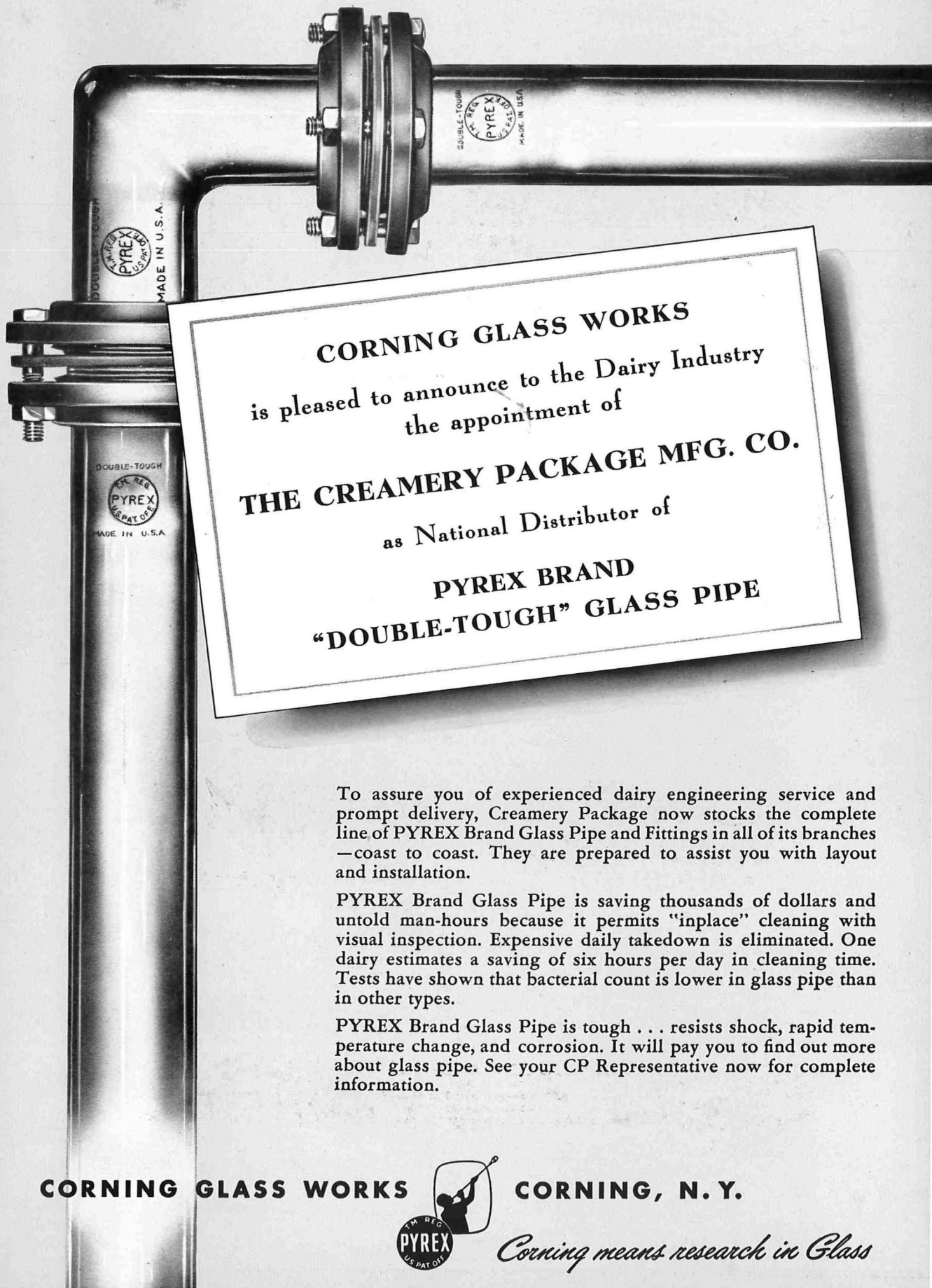

CORNING GLASS WORKS
is pleased to announce to the Dairy Industry
the appointment of
THE CREAMERY PACKAGE MFG. CO.
as National Distributor of
PYREX BRAND
"DOUBLE-TOUGH" GLASS PIPE

To assure you of experienced dairy engineering service and prompt delivery, Creamery Package now stocks the complete line of PYREX Brand Glass Pipe and Fittings in all of its branches — coast to coast. They are prepared to assist you with layout and installation.

PYREX Brand Glass Pipe is saving thousands of dollars and untold man-hours because it permits "inplace" cleaning with visual inspection. Expensive daily takedown is eliminated. One dairy estimates a saving of six hours per day in cleaning time. Tests have shown that bacterial count is lower in glass pipe than in other types.

PYREX Brand Glass Pipe is tough . . . resists shock, rapid temperature change, and corrosion. It will pay you to find out more about glass pipe. See your CP Representative now for complete information.

CORNING GLASS WORKS

CORNING, N. Y.



Corning means research in Glass

FIELD MEN

Endorse New
Johnson & Johnson
 Aids to **QUALITY**
MILK PRODUCTION



David Graham, Director of Field Men, Roberts Dairy, Omaha, Nebraska likes the new sanitary Rapid-Flo Carton Holder.

Typical of the comments received by Johnson & Johnson, since the recent introduction of the new formula Rapid-Flo, Fibre-Bonded Filter Disks in the Factory-Sealed Carton, Mr. Graham of Roberts Dairy says: "Only a company that gets its men into the milk house or barn would have discovered the need for such an improvement in filter disk packaging and storage. We have learned to look to Johnson & Johnson for leadership in aids to quality milk production."

NEW FACTORY-SEALED CARTON



Handy, flat pack of 100's, with a specially designed flap that closes to keep each Rapid-Flo Filter Disk sanitary and factory-fresh, clean to the last disk. Easy to pick up, carry and store. Also available in the 300 put-up (3 cartons of 100 banded together).

NEW SANITARY CARTON HOLDER

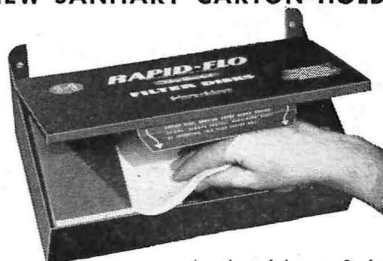

Another Johnson & Johnson exclusive, sloping lid closes automatically after filter disk is removed. Sanitary high lustre finish sturdy metal container for the original factory-sealed Rapid-Flo carton. Ask the Johnson & Johnson Field Service Representative for a demonstration.

**The New Formula Rapid-Flo Fibre-Bonded Filter Disk
 now provides an even more reliable Farm Sediment Check-Up.**

DAIRY FILTERS DEPARTMENT

Johnson & Johnson

FILTER PRODUCTS DIVISION

4949 W. 65th Street

Chicago 38, Illinois

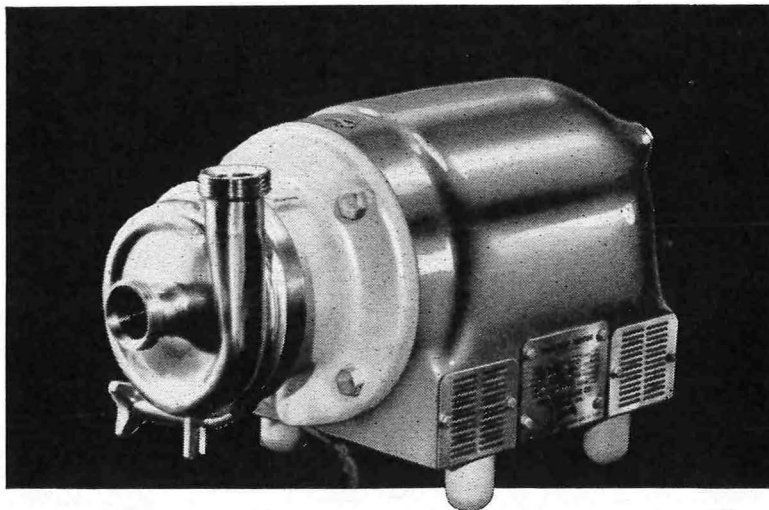

Look at the New FlexFlo Sanitary Pump

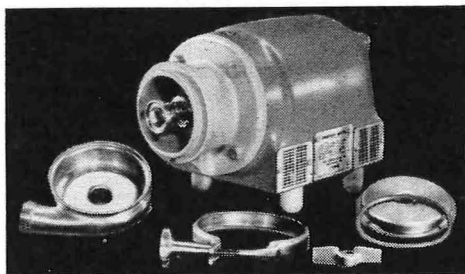

The new Flexflo disassembles easily for cleaning—is just as readily reassembled.

Send for Information. Ask your Cherry-Burrell representative or write direct to general offices for more information on the new Flexflo.

Flexflo pumps—long the leading sanitary pumps on the market—now offer still more advanced design features that mean higher efficiencies, greater sanitation, easier cleaning and less maintenance. The new Flexflo involute pump body enables them to pump the same volume with less horsepower. They are equipped with the new type sanitary motor. This pump meets 3A Code standards. Capacities to 70,000 lbs. per hour.

6 IMPORTANT IMPROVEMENTS

- 1 New Balanced Sanitary Rotary Seal—longer lasting.
- 2 Heavier Construction—less danger of crushing or distortion. Better gasketing—seals with less pressure.
- 3 All Welded—no soldering.
- 4 More Sanitary Stainless Steel Construction—easy to clean—no sharp corners or hard-to-reach surfaces.
- 5 New Sanitary Motors—totally enclosed and splash-proof.
- 6 Higher Efficiencies.

CHERRY-BURRELL CORPORATION

General Sales and Executive Office:

427 W. Randolph Street, Chicago 6, Ill.

Milk and Food Plant Equipment and Supplies

FACTORIES, WAREHOUSES, BRANCHES, OFFICES OR DISTRIBUTORS

AT YOUR SERVICE IN 56 CITIES



trendmaker in a great industry

How close does your filler come to these *average* Cemac figures?

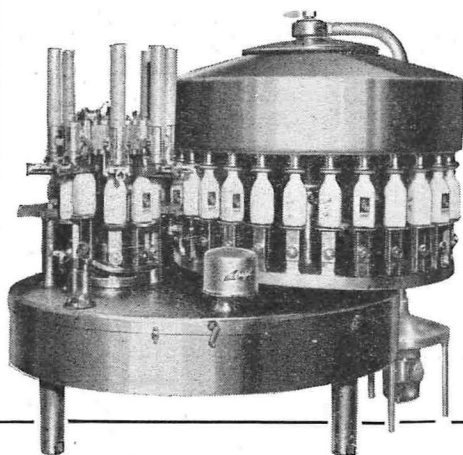

CREAM LINE MILK	135 BPM
HOMOGENIZED MILK	130 BPM
CHOCOLATE MILK	125 BPM
20% CREAM	120 BPM

These are only rated capacities for Cemac 28 . . . they are exceeded in many dairies from coast to coast.



What you see on the chart above are speeds we know Cemac 28 will attain. But there are many Cemac owners who are finding this filler regularly exceeds them. It's easy to realize the balanced production these dairies are getting. With all types of products coming down the line at such speeds . . . production keeps moving throughout the plant. None of the other machinery has to slow down because of the filler . . . the dairy operator gets his money's worth from all his equipment throughout the daily run.

If you're not satisfied with your bottling operation, get the complete performance figures on Cemac. Compare them with the filler you are now using or with any other filler on the market. Once you've seen what Cemac can do . . . you'll want a Cemac in your plant.

CROWN CORK & SEAL CO. • Machine Sales Division • Baltimore 3, Md.

Cemac **VACUUM MILK FILLER**
The Greatest Performer of them all

... AND REMEMBER, THE GREATEST COMBINATION OF THEM ALL IS CEMAC AND THE DACRO P-38 CAP!

Built in 2 sizes:
CEMAC 14
CEMAC 28

HELP MILK-PRODUCERS TO PROTECT MILK QUALITY THREE WAYS

WITH *Perfection* DUBL-CHEM-FACED MILK FILTER DISCS'
NEW "*Tripl-Filtring*" ACTION

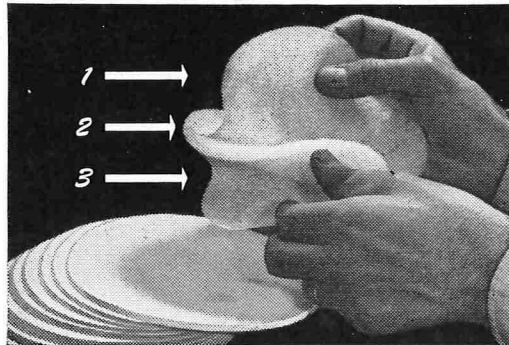

- 1—THE TOP SURFACE Filters
- 2—THE CENTER AREA Filters
- 3—THE BOTTOM SURFACE Filters

Only DUBL-CHEM-FACED Filter Discs provide this "Tripl-Filtring" action . . . fast and thorough . . . at less cost . . . fewer filters required . . . dependable protection of milk quality is assured three ways!

NO OTHER FILTER DISCS CAN CLAIM TO FILTER MILK BETTER



Milk filters generally depend solely on a single thickness of filtering cotton to catch sediment as milk passes through. In DUBL-CHEM-FACED "Tripl-Filtring" construction, however, two important "extras" are provided, because in addition to the super-thick center area of specially carded cotton, the toughened TOP and BOTTOM surfaces both act as filters, too! Highest quality, low in cost, easy to use, popular with top grade milk producers . . . worthy of your endorsement.

Write for samples

SCHWARTZ MANUFACTURING CO., Two Rivers, Wisconsin
Manufacturers of *Perfection*, *Blue Streak*, *Elgrade*, and *DUBL-CHEM-FACED* Filter Discs, *Rolls*, *Bags* and *Tubes* . . . *Fray-Seal* Cheese Bandages and *Circles* . . . and a complete line of cotton goods for the Dairy Industry.



NOW! **SMALLER COMMUNITIES, TOO, CAN HAVE SEALRIGHT SANITARY PROTECTION**

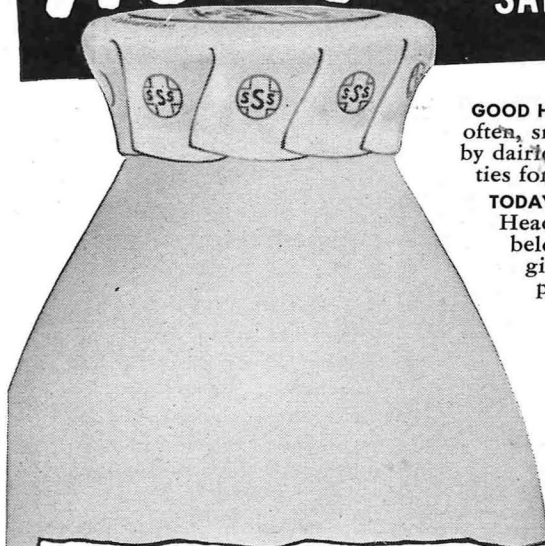

GOOD HEALTH IS EVERYBODY'S BUSINESS! All too often, smaller communities have been served by dairies which lack the most modern facilities for health protection.

TODAY THINGS ARE DIFFERENT! The new Single Head Sealon Applying Machine (shown below) has been expressly designed to give smaller communities the same milk protection found in the most progressive larger cities.

Because the SEALON HOOD protects the milk bottles' pouring surface all the way, *it has been found eminently acceptable to ALL Boards of Health!*

NEW SEALON APPLYING MACHINE IS IDEAL FOR SPECIALTY HOODING

Many dairies have found this machine particularly adaptable for specialty hooding. Famous Sealright Sanitary Protection is now possible for gallon milk containers, cottage cheese jars and even two-quart rectangular bottles.

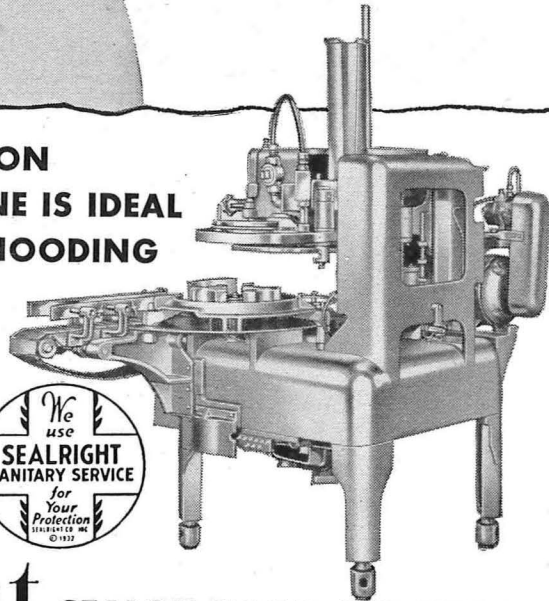

Sealright SEALON HOOD CLOSURES

SEALRIGHT CO., INC., Fulton, N. Y.; Kansas City, Kansas; Sealright Pacific Ltd., Los Angeles, Calif.; CANADIAN SEALRIGHT CO., LTD., Peterborough, Ontario, Canada.



**After the bath...
sterile containers**

In an atmosphere of filtered air Canco Paper Milk Containers are mechanically dipped into a bath of molten hot paraffin.

Still in sterile air, the containers are drained, cooled . . . and their caps are *sealed*. Not until then are the containers brought into the open to be inspected and packed in paper-lined cartons, which themselves are sealed, for shipment to dairies.

The technique of paraffining and closing Canco Paper Milk Containers under controlled sanitary conditions is the reason why with the Standard Method Rinse Test over 85% of the containers show completely negative plates.

Under the same test only a slightly higher percentage of sterilized control flasks are found to be negative, indicating that practically all the Canco containers are sterile.

American Can Company 

100 PARK AVENUE, NEW YORK 17, N. Y.

NEW YORK • CHICAGO • SAN FRANCISCO • HAMILTON, CANADA

ONE for ALL...

and *all* from one!

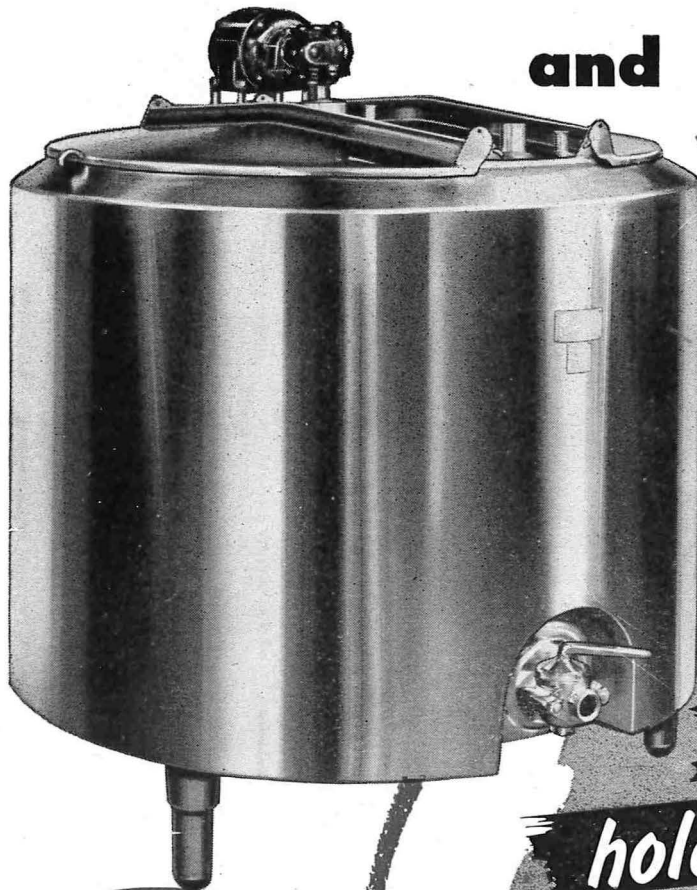

- MARKET MILK
- CREAM
- ICE CREAM MIX
- BUTTER-MILK
- CHEESE-MILK
- CHOCOLATE MILK
- STARTERS

heat! *cool!*

hold! *pasteurize!*

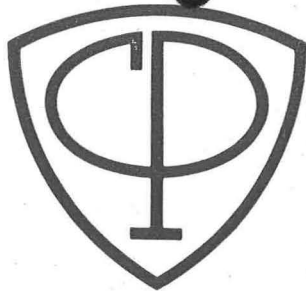

Multi-Process Tanks

**SERIES
40**

CP Multi-Process Tanks increase the flexibility of your operations by their ability to process a variety of products. CP's *two speed, off-center* agitator provides proper balance of good mixing action and ample velocity for efficient heat transfer. CP's all welded, stainless

steel construction reduces clean-up time for the change-over to a minimum.

In planning for the long pull, you'll be profit wise to choose CP Multi-Process Tanks. Either vapor heat or pump circulation film heat. Capacities from 50 to 1000 gallons (1000 Gal. size-vapor heat only).

Series 40 Tanks may also be had with refrigerated side walls for cooling and holding only.

CP Multi-Process Tanks are available with scraper blade agitators for heating and cooling heavy viscous products such as sweetened condensed milk.



THE *Creamery Package* MFG. COMPANY

General and Export Offices: 1243 W. Washington Blvd., Chicago 7, Illinois

Atlanta • Boston • Buffalo • Chicago • Dallas • Denver • Houston • Kansas City, Mo. • Los Angeles • Minneapolis • Nashville • New York • Omaha • Philadelphia • Portland, Ore. • St. Louis • Salt Lake City • San Francisco • Seattle • Toledo, Ohio • Waterloo, Ia.

CREAMERY PACKAGE MFG. CO. OF CANADA, LTD.
267 King St., West, Toronto 2, Ontario

THE CREAMERY PACKAGE MFG. COMPANY, LTD.
Mill Green Road, Mitcham Junction, Surrey, England

**REPLACE
OR
REPAIR
NOW**

EDITORIAL NOTES

SYNTHETIC REFERENCE AGAR

AT a meeting of the Sub-Committee on Standard Methods for the Examination of Dairy Products of the American Public Health Association (A. H. Robertson, *Chairman*) on February 1, 1950, interest developed in the idea of a Synthetic Reference Agar against which candidate milk-colony agars might be standardized or evaluated.

It had been the experience of Michael J. Pelczar, J. Howard Brown, Harriet D. Vera, and others that, using the same samples of milk, comparative colony counts in different lots of the standard Tryptone Glucose Extract Milk (TGEM) agar might show differences far greater than ± 5 percent. At the 78th meeting of the American Public Health Association in St. Louis, 1950, Leon Buchbinder, Vivian Pessin, Yetta Barris, and Louis Pincus reported as much as 17 percent variation from the geometric mean.

Following the Committee meeting of February 1, 1950, Pelczar and Brown investigated the possibility of devising a synthetic medium for use as a reference standard. Their results were reported at the 78th meeting of the APHA. The synthetic medium described (known as S₄) contained 18 amino acids, 8 vitamins, 3 purine bases, 2 pyrimidine bases, K₂PO₄, MgSO₄, glucose, and agar, all pure chemical substances except the agar. It might seem that this is an unduly complex mixture as compared with other synthetic media described in the literature but it must be borne in mind that the latter have been devised to support the growth of selected groups of bacteria and not quantitatively whereas a milk count medium must support the growth of all species which may be found in milk and

quantitatively. Not sterile skim milk was added to the synthetic medium as a nutritive substance but was contained in the TGEM used for comparison.

The Sub-Committee of the APHA distributed to 17 cooperating laboratories samples of S₄, TGEM, and a number of candidate media, all under code designation. The results of milk counts were subjected to statistical analysis by Vivian Pessin and reported at the 78th meeting of the APHA by Samuel R. Damon and C. A. Abele. Pelczar and Brown had found that if incubated for 96 hours the S₄ plates yielded colony counts and size closely similar to 48-hour counts in TGEM and by the addition of sodium ethyl oxalacetate to the S₄ formula the time of incubation might be reduced to 72 hours for comparable results. The results of the APHA tests reported by Damon and Abele showed a ± 5 percent agreement between the S₄ and TGEM counts, also that the sample of Trypticase Glucose Extract Milk agar (BBL) gave similar agreement.

Obviously different lots of TGEM are not a sufficiently rigid standard and it is suspected that this is a fault of any peptone medium. Such a synthetic medium as S₄ should provide a more rigid standard. It is not proposed that a synthetic medium be used for routine milk counts but that it be used only as a "Reference Standard" for the acceptance of individual lots (not brands) of milk colony count agars. It would be for the appropriate Committee of the APHA to set up machinery for having lots of candidate media evaluated and properly labeled. One can not operate with an elastic standard.

J. HOWARD BROWN

SYNTHETIC CULTURE MEDIA FOR AGAR PLATE COUNTS

IN the 1918 *Journal of Bacteriology*, page 112, Leo F. Rettger stated in his presidential address to the Society, "A most satisfactory culture medium, or one that will of itself eliminate bacterial lag, will be a medium which furnishes satisfactory substitutes for the intermediate bodies, in the form of amino acids and perhaps amines of simple composition, and also certain growth-accessory substances. When such an artificial medium is available, our methods of enumerating * * * bacteria by the plating process will be attended with much greater success than they are now."

Your Editor, J. Houston Shrader, quoted the above in his report on Media Composition and Bacteria Counts of Milk, in the *Fifteenth Annual Report of your Association*, which at that time was under a former title. The quotation is repeated to show the fundamental and constructive thinking of these scientists.

With these and other sources of information as building blocks, J. Howard Brown and Michael J. Pelczar report in this issue of the JOURNAL on an almost incredible achievement of assembling in suitable proportion a group of amino acids, vitamins,

purine bases, pyrimidine bases, organic and inorganic salts, and dextrose with agar, which combination as a plating medium, synthetic in composition except for the refined agar ingredient therein, yields a colony productivity on pasteurized milks that averages only slightly below that given on the official plating medium currently recognized by the American Public Health Association. It is a distinct credit to the authors not only to have had the vision, but most of all to have accomplished so nearly a realization of that vision.

The Subcommittee on Standard Methods for the Examination of Dairy Products of the American Public Health Association has encouraged the authors in their realization, because previously there has been no official reference standard by which colony productivities of candidate media or of successive factory batches of the same brand of medium could be determined. Comparison productivities under the direction of this Subcommittee in 1950, using the original S4 synthetic medium of the authors and the present official Standard Methods

medium on both raw and pasteurized milk, have disclosed an averaged productivity by the former approaching 95 per cent of that by the latter. The present cost of the ingredients for the synthetic medium prohibits its use for routine determinations. The distinct advantage of having a synthetic medium for reference purposes is its reproducibility.

Earle K. Borman, of the Connecticut State Health Laboratories, is now trying to organize a small group to study synthetic media. The aim of this study is to determine what combination of ingredients is most satisfactory to give a colony productivity essentially identical to that given by the present plating medium and then to recommend to the American Public Health Association that such a combination be recognized as the standard synthetic medium for official reference use.

The report by Brown and Pelczar is a noteworthy milestone in the progress to standardize methods for the examination of dairy products.

A. H. ROBERTSON

"BILL PALMER"*

Some fourteen years ago Bill Palmer with a vision brought forth to a meeting the proposal to establish a journal for sanitarians. So firm was his belief that he invested personal funds to prove that it could be done. He brought fully printed samples. With this guidance, the Association embarked upon the publication of this *Journal*. Over the years, Bill Palmer expended the labor of love for the *Journal*, soliciting and arranging advertising, and worrying about the numerous regulations on printed matter, postal laws, date lines, and finances. From the seed of his vision developed the outstanding journal of its kind, the medium by which the objectives of all sanitarians is attained, understanding of the work of the profession.

An association does not run by itself. The members, the committees, the officers must think, worry, sweat, to achieve the things that need to be done. We all must play our part in the affairs of this *Journal*. Its problems he made his own, as a father to his family. We in the Association shall miss his counsel, his "orations," his momentary look of askance and raised eyes, but we shall continue to share, with memory of him, the *Journal*. Our gratitude cannot cease.

K. G. WECKEL
President, I.A.M.F.S.

Bill Palmer ("William of Orange") was one of the old friends in milk sanitation for whom I had come to have a feeling of real affection. One of his outstanding characteristics was his unusual sense of humor. To me his passing means the loss of another good friend. To the Association, however, it is much more than that. He and Dr. Shrader, together, were almost wholly responsible for the establishment of our *Journal*. Together they have made it the popular and successful publication it is today. There, no doubt, will be another managing editor—but never another Bill Palmer.

PAUL B. BROOKS

Flags are flying at half-mast and the whole world of milk sanitarians is in mourning for one of their oldest and most beloved members. His wide knowledge, sound judgment and vast experience will be sadly missed in the councils of the Association. No longer will his name appear as business manager of the *Journal* which he helped found and to which he gave his full measure of devotion.

Bill Palmer and milk sanitation are synonymous to the older members of the Association. He stood for the best in all things at all times regardless of the opposition or the odds. Men like Bill don't happen along every day. They come once in a century.

Bill, we are glad we knew and had the inspiration of your undying devotion to a great cause. We are going to miss you more than we knew.

F. W. FABIAN

* Mr. William B. Palmer, Managing Editor of this *Journal*, died suddenly on May 25. See obituary notice on page 125.

BILL PALMERS PASSING IS A DISTINCT LOSS TO OUR ASSOCIATION AND THE ENTIRE PUBLIC HEALTH PROFESSION. HE WAS LOVED FOR HIS SERIOUS AND THOROLY CONSCIENTIOUS DEVOTION TO HIS LIFES WORK AND IDEALS ENLIVENED BY HIS GOOD HUMORED FUN MAKING DISPOSITION. I ADMIRED BILL AND WILL MISS HIM GREATLY.

GEORGE W. PUTNAM

His name was William B. Palmer—"but the fellers called me Bill." Everybody in the milk industry in these parts—and many in the related fields of public health and civics—knew Bill. He liked people, and this interest kept him circulating, mixing, quipping. We all were exposed to his seemingly exhaustless repertoire of stories. His spirit was buoyant, always cheerful. His character was above reproach. He was the public officer whose integrity, honesty, and intelligence everyone respected. No taint of sordid deals besmirched his record. No double dealings, nothing "that maketh a lie," can be attributed to him. Honest, upright, conscientious, indefatigable in the public interest—he was the kind who had the confidence of both the industry and the public. He held it for 35 years. The City Hall at Orange, N. J., will be draped in mourning for a month.

THE ASSOCIATION OF MILK AND FOOD SANITARIANS, INC., has lost one of its most stalwart sons. He was its president in 1931-32. Many of its committees he chaired. At every meeting Bill was active, both on the floor and in the halls. He was no shrinking violet. He was deeply interested, broadly informed, and vocally expressive—much.

His greatest work for the Association was his fathering of the *Journal of Milk and Food Technology*. For several years in the 1930s, he tried to get the Association to undertake the publication of a periodical to replace its Annual Report series (which carried the papers that had been presented at the respective annual meetings). The membership numbered about 250, a figure that had held rather constant for many years. Encouraged by the then President, Dr. J. G. Hardenbergh, he presented at the 1937 convention, at Louisville, Ky., a sample journal such as he believed the Association could handle. This Exhibit A, so to speak, was the first copy of this *Journal*. He had it printed on his own responsibility, and brought a bundle of copies, right off of the press, down to the train, barely making it. This constituted Volume 1, Number 1, 1937. The other members of the Committee were: C. Sidney

Leete, Dr. J. J. Regan, Dr. J. H. Shrader, and Dr. J. A. Tobey. From that day to the day of his death, he personally and single-handedly conducted all the business affairs of the *Journal*.

In the management of the *Journal*, he revealed his business ability. Never once was the publisher kept waiting for his money; regularly, we took our cash discount. He conducted all the business part of the *Journal*—advertisements (solicitation, contracts, rates, etc.), subscriptions, publication contracts and specifications, orders, etc.—without secretarial help of any kind. Regularly, night after night for these past thirteen and one-half years, he has typed his own letters, filled orders, sent out sample copies, billed our debtors, entered the accounts, thought and lived the *Journal*. The new format is his latest major contribution to the Association.

The old guard dies but it never surrenders. He wore himself out in the cause that he loved. Such loyalty, devotion, and ability—all mixed into a personality—are irreplaceable. We still cannot realize that he is gone. Probably we'll awaken to this only too soon. How we leaned on him! But his influence lives on. His work continues. We are encouraged by the memory of his devotion and his ideals.

Our grief slows us down. We think of what he meant to us. We see him bigger than his job. We see him encouraging the discouraged, giving helpful ideas to those who are in need (many a confused dairyman has been set straight and put on "the straight and narrow" by his constructive counsel, even to the laying out of plants). We see a healthier community—many persons living useful lives who but for his efforts would not be living. We see the milk industry where he touched it, better for his influence. We see his community, his state, his Association, the *Journal*—now going to 53 foreign countries—all helped and enlarged and strengthened because he lived and cared. This means vision, creativeness. This is an expression of a life that was divinely sparked. He left the scene a better one than what he had found.

J. H. SHRADER

Thirty-eighth Annual Meeting

GLENWOOD SPRINGS, COLORADO, Sept. 26-29, 1951

SYNTHETIC CULTURE MEDIA FOR REFERENCE USE IN DAIRY BACTERIOLOGY*

MICHAEL J. PELCZAR, JR., PH.D.
Associate Professor
University of Maryland

AND

J. HOWARD BROWN, PH.D., Sc.D.
Associate Professor Emeritus

Having noted that different lots of the same brand of milk plating agar showed considerable irregularity in colony counts of the same samples of milk, the authors devised a reproducible synthetic medium in dry form which might serve as a *Reference Standard* against which different lots of peptone media could be evaluated. Milk samples plated in this synthetic medium yielded colony counts comparable to those obtained in samples of the TGEM medium of two different manufacturers provided only that plates containing the synthetic medium were incubated longer to allow for the somewhat slower development of the colonies.

THE standardization of any bacteriological medium, from the standpoint of its chemical composition and hence its nutritive characteristics, in the strict sense of the word presents a difficult problem when such variable ingredients as peptone, meat extract, yeast extract, etc. are employed. This is particularly true when the medium is used for the cultivation of numerous species of bacteria from samples which may vary considerably both as to total number and types present. Such is the case with the present standard Aryptose-glucose-beef extract—milk (1 percent of skimmilk to be added) agar (TGEM) medium used in bacteriology.

Numerous individual studies and surveys have been conducted in the past in an attempt to arrive at a formula which would be superior to the tryptone glucose beef-extract agar (TGEM) since this medium possesses certain undesirable features (Black).

In such studies and under the present circumstances it is usual to evaluate all candidate media in terms of the corresponding performance of TGEM agar. The assumption must be made that all factory batches of media prepared according to the performance when tested with milk TGEM formula will give identical samples. That this assumption is correct, is improbable.

* Presented at the Coordinating Committee on Laboratory Methods of the American Public Health Association at the 78th Annual Meeting in St. Louis, Mo., November 1, 1950.

A more rational and scientific approach to this problem would be to assemble a medium of synthetic composition, consisting of pure chemical compounds, except agar, to serve as a "Reference Medium," against which candidate peptone media or all lots of the standard medium could be judged for suitability as milk count media. Such a "Reference Medium" would have the obvious advantage of being readily and exactly reproducible. To arrive at the formula of such a "Reference Medium" might well be a formidable task, but the tremendous accumulation of knowledge on bacterial nutrition during the past ten years does not make it seem impossible.

The experimental data which follow constitute preliminary attempts toward the development of such a "Reference Medium."

EXPERIMENTAL

In an attempt to formulate a medium of synthetic composition which might support the growth of most of the bacteria present in milk, we have elected to prepare what might be referred to as "shot gun" mixtures of amino acids, vitamins, purines, pyrimidines, salts, carbohydrate and agar. Selection of compounds, the amounts, and combinations, were based upon results reported for the growth of various microorganisms in chemically defined media. Generally, liter quantities of a medium were prepared employing conventional technics common to preparation of synthetic media for bacteriological studies. The media were sterilized by autoclaving for 10 minutes at 15 lbs pressure.

Evaluation of media prepared in the above manner was attempted by plating samples of raw and pasteurized milk in multiple sets of duplicates. One set of the duplicates would receive TGEM agar (1 percent sterile skimmed milk added) and the remaining sets would receive the experimental synthetic media. Plates were incubated at 35° C for



Dr. Michael J. Pelczar, Jr., was graduated from the University of Maryland in 1936, and received an M.S. from the same institution in 1938. He received his Ph.D. from the State University of Iowa in 1941 after majoring in bacterial nutrition and biochemical activity of microorganisms. He served as bacteriologist in the U. S. Army Sanitary Corps 1942-46, and has been on the staff of the University of Maryland Bacteriology Department since 1946.

48 hours, at which time colony counts were made and the size and countability of colonies in various media were compared. The plates were reincubated at the same temperature for an additional 24 or 48 hours (sometimes longer) and the colony count and colony size again determined. After several such trials it was decided to eliminate the use of raw milk samples as they did not provide a severe enough criterium for judging the performance of the synthetic mixes.

One of the first formulae which seemed to warrant more detailed study was the medium designated as S₄, the ingredients of which are presented in table 1. Additional quantities of this medium were prepared and pasteurized milk samples plated, in duplicate sets, using S₄ and TGEM agar containing 1 percent sterile skimmed milk. Incubations and recording of results were carried out as described earlier. Generally, five or ten pasteurized milk samples were plated on any one day. Approximately 100 samples have been examined to date, at various times of incubation. It is felt that the number of milk samples counted in the two media is not large enough to permit a valid statistical analysis. Therefore, a series of counts, typical of results obtained with the S₄ medium is presented in table 2.

Growth in the S₄ medium was extremely slow. Generally only a small percentage of the number of colonies appearing in the TGEM agar at 48 hours were countable in

INFLUENCE OF PENICILLIN IN MILK ON TOTAL AND COLIFORM BACTERIA PLATE COUNTS*

H. H. WILKOWSKE AND W. A. KRIENKE

Department of Dairy Science
Florida Agricultural Experiment Station
University of Florida
Gainesville, Florida

Storage of milk at 10° C for 72 hours that contained 1.0 unit of penicillin per milliliter of milk resulted in no significant increases in total plate counts while the counts increased considerably in control samples under similar conditions. Although this would indicate a preservative property of penicillin it is recommended that penicillin not be added to market milk for reasons which are discussed. Coliform plate counts were not affected by as much as 10 units of penicillin per milliliter of milk. A decrease in penicillin concentration in milk indicated possible production of a "penicillinase" by the coliform organisms.

PENICILLIN is best known for its activity against gram-positive microorganisms. The streptococci and micrococci (staphylococci) associated with bovine mastitis generally are found to be inhibited by this antibiotic.⁵ Various commercial preparations of penicillin are available for use in the treatment of mastitis, especially in those cases of inflamed udders where the gram-positive organisms are suspected of being the causative agents. After infusion of penicillin (ointment base) into cows udders, the milk drawn therefrom for the next few days has been found to contain sufficient amounts of penicillin to cause significant reduction of acid development in dairy starters. It has been observed that the lactic acid producing ability of *Streptococcus lactis* bacteria in starters was markedly reduced by the presence of as little as 0.1 unit of penicillin per milliliter of milk.^{6,7} Growth inhibition of lactic streptococci in commercial dairy starters, due to the presence of penicillin, is evidenced by slow or no acid production which results in uncoagulated vats of milk intended for the manufacture of cheese and buttermilk.

Milk sanitarians have observed instances of unusual decreases in bacterial plate counts of milk produced by the same dairyman; changes from relatively high counts to abnormally

low counts occurring over periods of only a few days. Questions have been raised regarding the possible effects of penicillin on bacterial plate counts of milk from cows treated with the antibiotic or when the antibiotic had been intentionally added to the milk as a preservative.⁴ The purpose of this investigation was to determine the influence of penicillin on the total and the coliform bacteria counts of milk. Effects of the antibiotic on *Escherichia coli* and *Aerobacter aerogenes* were studied by employing pure cultures of the organisms. Observations were made, also, on the inactivating effects of *Escherichia coli* on penicillin.

EXPERIMENTAL

In order to investigate the influence of penicillin on the total and coliform plate counts, samples of mixed raw milk (composite from several cows) were obtained from a herd of dairy cows known not to have been treated with penicillin or other antibacterial agents during a period of several months prior to this study. Known amounts of penicillin were added aseptically to various aliquot portions of these samples. Crystalline sodium penicillin "G" was appropriately diluted in sterile distilled water so that when 1 ml was



Dr. H. H. Wilkowske is Assistant Professor of Dairy Manufacturing at the University of Florida. He received his B.S. and M.S. degrees in 1940 and 1942, respectively, from Texas Technological College. He served as U. S. Navy officer for 4 years. In 1949 he received his Ph.D. degree in dairy bacteriology from Iowa State College. He is Secretary-Treasurer of the Florida Association of Milk Sanitarians.

added to 99 ml of raw milk the desired final penicillin concentration was obtained. Penicillin concentrations of 0.1, 1.0, and 10.0 International Units per milliliter and penicillin-free controls were employed. The samples were stored at 10° C (50° F) since this temperature permits slow bacterial growth in milk. The samples were plated at intervals selected to indicate trends in bacterial population changes.

Several trials were made, the milk in all cases coming from the same herd. Initial plate counts were different in the various trials since the milk was obtained on different days. Therefore, the results could be compared only with respect to general

TABLE 1
INFLUENCE OF PENICILLIN ON STANDARD PLATE COUNTS OF RAW MILK

Units of penicillin	Hours held at 10° C			
	0	24	72	144
Total count per milliliter				
0.0	22,000	45,000	490,000	330,000,000
0.1	"	39,000	54,000	180,000,000
1.0	"	18,000	17,000	86,000,000
10.0	"	14,000	17,000	320,000,000
Coliform count per milliliter				
0.0	1,100	470	1,000	340,000
0.1	"	660	830	260,000
1.0	"	700	580	240,000
10.0	"	540	930	280,000

* Florida Agricultural Experiment Station Journal Series No. 3, Willard M. Fifield, Director.

trends which were essentially the same in each trial. A representative trial is shown in table 1.

Prior to the addition of penicillin, the initial total count was 22,000 per ml and the coliform count was 1,100 per ml. There was a continual increase in the total count of the control sample during the six-day storage period but the coliform count decreased during the first 24 hours and then increased.

The presence of 1.0 unit or more penicillin per ml in the raw milk resulted in marked retardation of microbial growth for at least 72 hours. When only 0.1 unit per ml was present, growth was more rapid but was considerably less than in the penicillin-free control.

There was a drop in the coliform count after 24 hours at all levels of penicillin which was followed by an increase in count during the remainder of the storage period. The results indicate that coliform plate counts are not appreciably affected by concentrations of penicillin up to 10 units per ml. The decrease in the coliform counts after 24 hours storage did not appear to be the result of action of penicillin since the penicillin-free control showed a similar decrease.

In the second series of experiments, pure cultures of the coliform organisms *E. coli* and *A. aerogenes* were used. The cultures were grown at 35° C in autoclaved (15 pounds for 12 minutes) skim milk. Twenty-four hour cultures were used as inoculum after suitable dilutions had been made in sterile distilled water. In order to effect the highest degree of control of the numbers of organisms in each sample, autoclaved milk was divided into aliquot portions after a single portion had been inoculated. This was followed by aseptic addition of the various desired amounts of penicillin. Penicillin concentrations up to 1000 units per milliliter were used. The storage temperature was 10° C (50° F). The time intervals at which coliform plate counts were made and the results obtained are shown in table 2.

Initial counts of 840 and 430 per milliliter for the *E. coli* and *A. aerogenes*, respectively, were obtained. Unlike the coliform plate counts of raw mixed milk, when pure cultures of the two microorganisms were used, the penicillin-free controls did not show any decrease during the first 24 hours. Over a period of time

TABLE 2
INFLUENCE OF PENICILLIN ON *Escherichia coli* AND *Aerobacter Aerogenes* IN SKIMMILK

Units of penicillin	Hours stored at 10° C					
	0	24	48	72	96	144
<i>Escherichia coli</i>						
0	840	1900	17,000	360,000	1,700,000	63,000,000
10	"	1200	12,000	300,000	2,100,000	60,000,000
100	"	670	8,400	82,000	960,000	39,000,000
1,000	"	0	1*	0	0	0
<i>Aerobacter aerogenes</i>						
0	430	720	4,100	27,000	130,000	800,000
10	"	530	1,600	10,000	50,000	190,000
100	"	470	1,700	11,000	53,000	180,000
1,000	"	400	50	1	1	1

* Counts below 30 are averages of actual number of colonies on plates from one milliliter samples of material.

the number of *A. aerogenes* organisms was somewhat less than the *E. coli* organisms and more nearly like that of the coliform plate counts of raw mixed milk. At 10° C both cultures showed progressively higher counts over the six day period. In the milk containing 10 units of penicillin per milliliter, the two cultures exhibited slow growth. There was less growth in the presence of 100 units per milliliter. In the presence of 1000 units per milliliter both cultures were inactivated after a few days.

Since both the coliform plate counts of raw milk and those of the pure cultures showed that penicillin apparently lost its effectiveness in the presence of coliform organisms after a few days storage at 10° C, a study was made to determine the rate and amount of penicillin inactivation in milk by *E. coli*. One thousand units of penicillin were added per milliliter of milk. This was inoculated with *E. coli* and held at 10° C. At the end of 24 and 48 hours of incubation, portions of the material were heated to 80° C for 10 minutes; such treatment being sufficient to inactivate all remaining *E. coli* without inactivating the remaining penicillin.

Serial dilutions of this milk were made with penicillin-free milk to determine the highest dilution of heated test material that was active against a lactic acid producing culture. A commercial butter culture (starter) was used to supply the susceptible test organisms, using 3 percent inoculum in autoclaved skim milk. A standard curve, as outlined by Krienke,⁸ was prepared with known concentrations of penicillin. After incubating at 35° C for 4, 5, 6, and 7 hours, titratable acidity determinations were made. By observing the highest dilution of the unknown test material active against a lactic acid producing culture and comparing it to the known standard curve, it was possible to approximate the remaining penicillin activity in terms of units per milliliter of milk.

The coliform plate counts and the corresponding remaining penicillin activity are shown in table 3. Two trials were made, the milk in the first having an initial count of 850 per ml and assayed at the end of 24 hours and the milk in the second trial having a count of 130,000 and held for 48 hours prior to penicillin assay. It was found that although the control *E. coli* counts increased,

TABLE 3
INFLUENCE OF *E. coli* ON PENICILLIN ACTIVITY
(Skim milk medium at 10° C)

Trial	Coliform count		Penicillin units	
	0 hours	24 hours	0 hours	24 hours
<i>E. coli</i> +penicillin	850	3	1,000	200
<i>E. coli</i> only	"	17,000	—	—
Trial 2	0 hours	48 hours	0 hours	48 hours
<i>E. coli</i> +penicillin	130,000	300	1,000	80
<i>E. coli</i> only	"	5,000,000	—	—

the test samples containing 1000 units of penicillin decreased in numbers of coliform organisms. The penicillin activity also decreased over periods of 24 and 48 hours from 1000 to 200 and 80 units per ml respectively. In the two trials the inoculums used were 10^6 and 10^4 dilutions of a 24 hour *E. coli* skim milk culture. Whether penicillin inactivating material was carried over with the inoculum has not yet been determined.

DISCUSSION

The presence of 0.1 unit of penicillin per ml in raw milk has been found to influence normal microbial growth at 10° C. One unit of penicillin per ml was sufficient to retard growth for three days. Higher penicillin concentrations appear to lower the total plate counts of milk for three days. When the predominating organisms in milk are lactic streptococci inhibition by less than 1.0 unit per ml of penicillin has been observed.^{6,7} Thus the presence of 1.0 or more units of penicillin in market milk results in a temporary preservative action. Since the total plate counts were high after six days it appeared that some of the sensitive organisms had become penicillin resistant. Various naturally resistant types of microorganisms probably also were present. Eagle and Masselman³ showed that organisms surviving penicillin action did not resume multiplication immediately but exhibited a period of bacteriostasis during which the numbers were relatively constant. They report this influence on staphylococci, streptococci, and diplococci strains. Curran and Evans² reported the preserving action of penicillin in milk containing viable bacterial spores and concluded that penicillin had no application in the preservation of food. Foley and Byrne⁴ pointed out that adding penicillin to milk may be advantageously employed as an aid in the maintenance of quality in certain dairy products but added that penicillin should not be utilized as a substitute for cleanliness or for established sanitary practices. However, because of the nominal cost of penicillin, illicit use may occur and should be guarded against by milk sanitarians. Addition of 1.0 unit of penicillin per ml to milk would cost at current prices approximately ½ cent per gallon. This "adulteration" would be suffi-

cient to inhibit significantly the growth of the normal predominating bacterial flora in milk for several days.

Although penicillin does exhibit some temporary inhibitory action against some types of microorganisms present in milk, lowered total plate counts do not necessarily indicate that the overall quality of the milk has been preserved. Good quality dairy products will have low total bacteria counts when properly handled and stored, while poor quality milk should not be masked by the use of penicillin or any other preservatives to reduce the total plate counts. It is doubtful whether many, if any, official regulatory bodies would sanction the practice of intentional addition of penicillin to either raw or pasteurized milk because of the possible abuses to which the practice might lead.

The numbers of *E. coli* and *A. aerogenes* organisms present in raw milk were not appreciably affected by as much as 10 units of penicillin per ml. It is generally recognized that penicillin is occasionally ineffective in the treatment of mastitis caused by the gram-negative coliform organism *E. coli*. Concentrations of 100 units showed temporary restraining of growth and 1000 units was sufficient to inactivate the microorganisms after a few days when the initial counts were under 1000 per ml. In cases in which the penicillin concentration was sufficiently low to permit some coliform growth the activity of the antibiotic was gradually lessened.

Abraham and Chain¹ have reported that *E. coli* produces the enzyme "penicillinase" which inactivates penicillin. Krienke⁸ has employed a commercially prepared penicillinase in devising a test for detecting and assaying penicillin in milk.

The presence of *E. coli* in milk appears to have an influence on high (1000 units/ml) concentrations of penicillin in milk, bringing about a reduction in penicillin activity within a few days. It appears that, although penicillin does have some influence on reducing the total count of raw milk temporarily, the presence of coliform organisms will bring about the inactivation of penicillin and possibly allow a later increase in bacterial counts. Such increase would occur only if the penicillin sensitive organisms are able to re-

gain their normal functions or if recontamination with such organisms takes place after the penicillin has been inactivated by the penicillinase produced by *E. coli*. The coliform plate counts appear not to be appreciably influenced by penicillin; however, the coliform organisms present after a given length of time accounted for only a relatively small fraction of the total number of microorganisms present in the raw milk.

CONCLUSIONS

1. A concentration of one unit of penicillin per milliliter in raw mixed milk was sufficient to significantly retard microbial growth during a three day storage period at 10° C.
2. Although a temporary preservative action was obtained due to the action of penicillin on the susceptible lactic streptococci in milk, it was recommended that penicillin not be used in market milk as a preservative because of the possible abuses to which such practices might lead.
3. Coliform organisms were not significantly influenced by as much as 10 units of penicillin per milliliter of milk.
4. The significant reduction of the activity of the penicillin in milk after two days storage at 10° C apparently was due to a "penicillinase" produced by *E. coli* with which the milk had been inoculated.

LITERATURE CITED

1. Abraham, E. P. and Chain, R. Further Observations on Penicillin. *Lancet*, 241, 177-188 (1941).
2. Curran, H. R. and Evans, F. R. The Activity of Penicillin in Relation to Bacterial Spores and the Preservation of Milk. *J. Bact.*, 52, 89-98 (1946).
3. Eagle, H. and Masselman, Arlyne D. The Slow Recovery of Bacteria from the Toxic Effects of Penicillin. *Ibid.* 58, 475-490 (1949).
4. Foley, E. G. and Byrne, J. V. Penicillin as an Adjunct to the Preservation of Quality of Raw and Pasteurized Milk. *J. Milk and Food Technol.* 13, 170-174 (1950).
5. Foley, E. G., Lee, S. W. and Epstein, G. A. The Effect of Penicillin on Staphylococci and Streptococci Commonly Associated with Bovine Mastitis. *J. Milk Technol.* 8, 129-133 (1946).
6. Hunter, G. J. E. The Effect of Penicillin on Lactic Streptococci. *J. Dairy Res.*, 16, 39-45 (1949).
7. Krienke, W. A. Penicillin in Milk. *Amer. Milk Rev.*, 11, (12), 24-25 (1949). *Milk Plant Monthly*, 38 (12), 44 (1949). *The Dairy World*, 28 (7), 42 (1949). *South. Dairy Prod. Jour.*, 46 (6), 32 (1949). *Milk Dealer*, 39 (2), 126 (1949).
8. Krienke, W. A. Unpublished report being prepared for publication. (Available in mimeographed outline form).

THE RELATION OF SOIL FILM BUILDUP AND LOW SURFACE WETTING PROPERTIES TO PLASTIC AND CHINA SURFACES

G. J. HUCKER, ARTHUR J. EMERY, AND ELIZABETH WINKEL

*New York State Agricultural Experiment Station
Cornell University, Geneva, New York*

THE average ease with which soil may be removed from surfaces remains the most significant problem of sanitation. The judgment of the operator as a result will be based primarily on the presence or absence of a visible film which may accumulate on the surface of utensils and equipment over long usage.

Dishwashing still remains the pilot procedure, the results of which are applicable to the broader field of general cleaning. Operations in which a mechanical washer is used are much easier to control than procedures in which hand washing is the regular routine. With the mechanical dishwasher the operations are more or less standardized, and obviously results in this field are altogether repeatable. In the case of hand washing, the human element becomes a factor, and day to day efficiency of operation varies over a wide area.

In studying the relative accumulation of film on surfaces with low wetting properties, plastic discs and plates were used, while overglazed china was used as a surface with high wetting properties. Consideration must be given to a number of factors when film build-up is observed on such surfaces, the most important being the securing of results which are repeatable under any given circumstance. In addition, the various soil ingredients may have different affinities for plastic and china, and consequently studies of this nature must be specific rather than general.

Studies were made on the relative ability of fats and proteins to adhere to plastic and china surfaces as well as the ability of films to accumulate over a series of cycles of soil-wash-rinse operations.

The criteria of efficiency of wash or the build-up of film on eating utensils is rather indefinite and not altogether possible of numerical recording. In the current study, visi-

ble observation served as the index of the presence of film.

Fats—One of the most difficult food ingredients to remove from surfaces are the various types of fats. The procedure followed in the experiments conducted in this investigation was to soil plastic and china plates and discs with butter, beef, and mutton fats as the soiling material and spread over the test discs and plates to be used. The fat film was stained with Sudan III prior to the washing in most instances. The staining procedure many times indicated the presence of fat films when unstained control plates gave no evidence of such a film present. Wide variation was found in film build-ups, particularly in the hand washing experiments due obviously to the degree of scrubbing. In the case of the mechanical washers the results were much more repeatable when the conditions were fairly well controlled. It was found (plates I and II) that with the exception of mutton, fats adhere much more readily and were much more difficult of removal from plastic than from china under similar conditions.

When pure mutton fat alone was employed the results between plastic and china were more nearly comparable. It should be stated that mutton, due to its high melting point, is generally considered the most difficult to remove from the dish. In the current studies, however, when mutton fat and beef were mixed, the adherence to plastic was much more pronounced than to china.

Protein—Nearly two hundred observations were made on the relative adherence of protein mixtures to plastic and china. These proteins centered primarily around skim milk and egg white. In all of these studies, skim milk and egg white when applied to plastic and china prior to washing were removed at



Dr. George J. Hucker, Professor of Bacteriology, New York Agricultural Experiment Station (Cornell University), Geneva, New York.

approximately the same fate from both surfaces.

Semi-permanent film on plastic—Plastic surfaces due to their difficulty to wet adequately will retain the initial soiling film more readily than china. Subsequent soils are then built up on the original film.

A larger number of dishes were tested in which either whole milk or the standard soil (peanut butter, 40 grams; butter, 40 grams; lard, 40 grams; evaporated milk, 60 grams, and distilled water, 200 ml) were used as the soiling medium and passed through a series of washes. In this series the plates were not resoiled between each wash but were soiled at the beginning of the serial washing. It was found (tables 1 and 2) that the original soil was retained very tenaciously on the plastic but was removed on the china, indicating that the adherence between the soil and the plastic was greater than between the soil and china.

Under actual operating conditions, eating utensils are repeatedly soiled. This will allow a gradual build-up on the utensils unless the washing procedure is exceptionally efficient or the eating utensils easily cleanable. The procedure in these experiments involved soil-wash-rinse-dry cycles through a series of several cycles to allow the build-up film.

When a series of plates and china dishes (table 3) was passed through seventeen cycles of soil-wash-rinse-

TABLE 1

RELATIVE CLEANING ABILITY OF CHINA AND PLASTIC USING STANDARD SOIL AS SOILING MEDIUM AND DRIED ON SURFACE

Number of serial washes after initial soiling with standard soil	Visual appearance of stained film	
	Plastic	China
1	+	+
2	++	++
3	+++	++
4	++	-
5	++	-
6	++	-
7	++	-
8	++	-
9	++	-
10	++	-
11	++	-

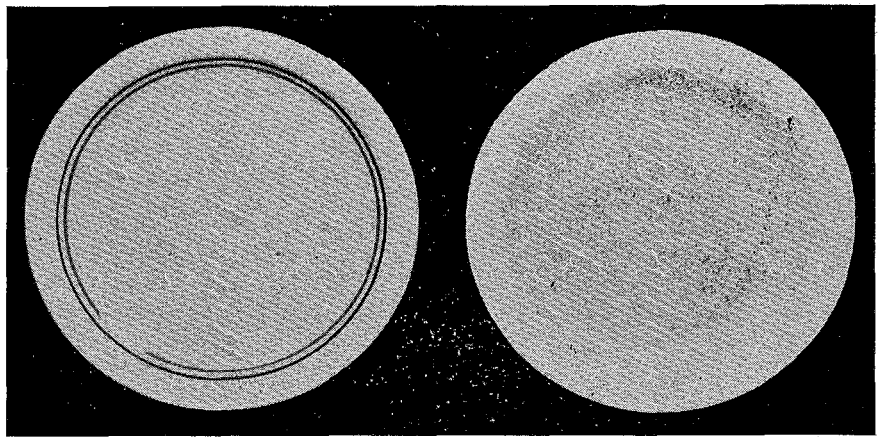

Plate 1. Relative retention of film on china and plastic plates when soiled with butter prior to mechanical washing.

TABLE 2

RELATIVE CLEANING ABILITY OF CHINA AND PLASTIC USING WHOLE MILK AS SOILING MEDIUM AND DRIED ON SURFACE

Number of serial washes after initial soiling with whole milk	Visual appearance of stained film	
	Plastic	China
1	±	-
2	+	±
3	++	-
4	++	-
5	++	-
6	++	-
7	++	-
10	++	-

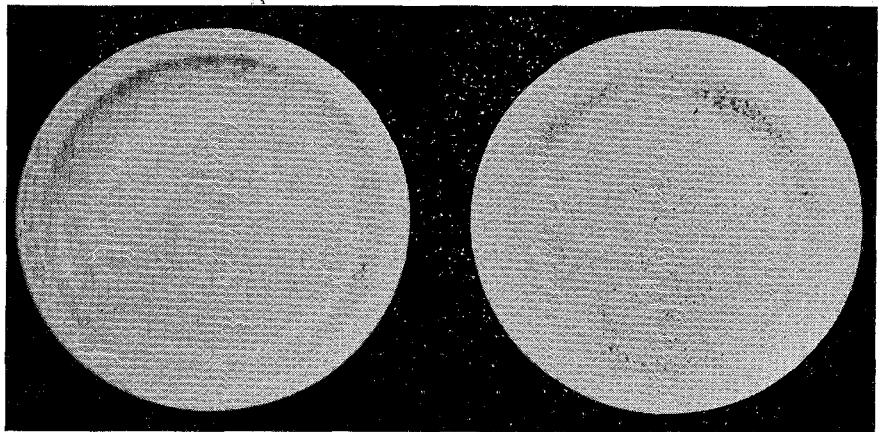

Plate 2. Relative retention of film on china and plastic plates when soiled with a beef-mutton fat mixture prior to mechanical washing.

steps, and a visible observation made (table 3) with regard to film build-up following each cycle, using whole milk as the soil medium, it was found that the plastic dishes quickly built up films while the china remained visually film free.

A repetition of these studies using a standard soil (table 4) as the soiling medium gave approximately the eighth or ninth cycle in contrast to the thirteenth cycle in the case of whole milk.

In order to study further the end point at which a visible film could be determined on both plastic and china dishes when a series of such soiling cycles was employed, a large number of trial series were studied (table 5). It was found that using a standard soil, the plastic generally began an accumulation of a visual film after the second cycle of soiling. In contrast, from thirteen to fifteen cycles were necessary on the china dishes before visible films could be noted.

Film variation—Under any washing operation there develops considerable variation in the retention

TABLE 3

RELATIVE FILM BUILD UP ON PLASTIC AND CHINA WITH CONTINUED SOILING WITH WHOLE MILK

Number of soil, wash and rinse cycles	Visual appearance of film, using whole milk as soil*	
	Plastic	China
1	+	-
2	+	-
3	++	-
4	++	-
5	++	-
6	++	-
7	++	-
8	++	-
9	++	-
10	++	-
11	++	-
12	++	-
13	++	-
14	++	++
15	++	+++
16	++	++++
17	++	++++

*=Average of ten plates.

TABLE 4

RELATIVE FILM BUILD UP ON PLASTIC AND CHINA WITH CONTINUED SOILING WITH STANDARD SOIL

Number of soil, wash, and rinse cycles	Visual appearance of film, using standard soil as soil*	
	Plastic	China
1	±	-
2	+	-
3	+	-
4	++	-
5	++	-
6	++	-
7	++	-
8	++	+
9	++	±
10	++	+++

*=Average of ten plates.

of film on the dish. To study this variation, a series of plastic and china dishes was passed through thirty soil-wash-rinse cycles and an observation made after each cycle

TABLE 5

NUMBER OF CYCLES OF SOIL-WASH-RINSE REQUIRED FOR INITIAL VISUAL APPEARANCE OF FILM USING STANDARD SOIL

Trial	Number of utensils	Number of cycles of soil, wash, and rinse necessary before visual films can be noted using standard soil			
		Plastic		China	
I	10	1	2	21	18
II	9	2	1	17	18
III	10	1	2	16	19
IV	8	2	1	14	16
V	10	1	1	15	13
VI	10	1	1	15	13
VII	9	1	2	11	12
VIII	10	2	2	19	19

using the standard soil as the soiling media. It was found (table 6) that considerable variation, dependent upon the many minor factors in the operation of the washer, was evident in the case of the china dishes when such large numbers of soiling cycles were employed. On the other hand, regardless of the number of cycles, the film remained more or less constant on the used and unused plastic dishes.

It was found also that insofar as an adherence of soil films was concerned, the length of the time which plastic plates were used is not a factor in film retention. In other

words, films will adhere as quickly and readily to new as to used plastic dishes.

CONCLUSIONS

1) Soil films build up faster on surfaces with low (plastic) wetting properties than on surfaces with high wetting properties (china).

2) When soiled with milk or beef and mutton fats, plastic does not clean as readily as china.

3) Soiled plastic after a series of washes cleans easier than cleaned plastic. The soiling is more easily removed from the collected films on

TABLE 6

FILM RETENTION ON PLASTIC AND CHINA ON LONG PERIODS (30 SOIL-WASH-RINSE CYCLES USING STANDARD SOIL)

Number of soil, wash and rinse cycles	Visual appearance of films using standard soil	
	Plastic	China
15	++	++
16	+++	+
17	+++	+++
18	++	±
19	++++	+
20	++++	+
21	++++	+
22	++++	++++
23	++++	++
24	++	++
25	++++	-
26	++++	++
27	++++	+
28	++++	+
29	++++	+
30	++++	+

the dirty plastic surface than the plastic itself.

4) Continued use and checking (other than appearance) has little effect on relative cleaning possibilities of plastic.

5) China varies greater (but at a lower level) in its film retention than plastic.

Synthetic Culture Media

(Continued from page 91)

TABLE 3

PAST, MILK COUNTS ON TGEM+S₄ PLUS SODIUM ETHYL OXALACETATE COLONIES/ML. x 10¹

TGEM	S ₄	S ₄
48 hrs.	48 hrs.	72 hrs.
138	93	140
140	38	137
7	12	48
204	78	209
24	5	20
265	192	262
80	15	295
15	5	21
92	22	105
128	3.5	115
106	165	215

ratios of certain constituents. It is conceivable that some of the first organisms to grow out might elaborate substances into the medium when they permit growth of the more fastidious types present which develop into colonies after the 72- or 96-hour incubation period.

In a study such as this it is apparent that many combinations of ingredients must be evaluated. It is not practical to prepare these experimental media in large quantities or to perform a large series of counts to determine the effect of each of these changes in the basic formula. At the same time, examination of only a few milk samples can result in erroneous interpretations, depending upon the particular bacterial flora represented in the samples se-

lected. An alternative scheme for assessing the performance of an experimental formula might be the use of single pooled milk samples or the use of a selected group of bacteria, in pure cultures, which might be representative of pasteurized milk flora. This approach is under investigation.

CONCLUSIONS

The conclusion seems unescapable that such a *Reference Medium* is needed if the irregular results inherent in peptone media are to be avoided.

REFERENCE

1. Black, L. A. Current Investigations of Laboratory Methods Used in Milk and Food Utensil Sanitation. *J. Milk and Food Technology* 11, 5 (1948).

layed growth might be due to sub-optimum concentration of some ingredient, the absence of some stimulatory growth factor, or the improper

A COMPARATIVE STUDY OF SIX AGARS PROPOSED FOR BACTERIAL PLATE COUNTS OF MILK

A REPORT OF THE COMMITTEE ON APPLIED LABORATORY METHODS*

VIVIAN PESSIN

Senior Statistician, Bureau of Records and Statistics, Department of Health, New York, N. Y.

AND

LUTHER A. BLACK

Chief, Milk and Food Sanitation Section, Environmental Health Center, U. S. Public Health Service, Cincinnati, Ohio †



Vivian Pessin; B.A., Hunter College; M.A., Columbia University. Statistician, Division of Milk Sanitation, New York State Department of Health, 1937-1941. Senior Statistician, New York City Department of Health, 1941 —. Referee (Statistical Consultant), Subcommittee on Standard Methods for the Examination of Dairy Products, A.P.H.A. Coordinating Committee on Laboratory Methods, 1951.

Because of faults noted by laboratory workers in the current A.P.H.A. Standard Methods agar, the Committee on Applied Laboratory Methods of the I.A.M.F.S. sponsored this study of proposed substitute agars. The Standard agar, another agar containing skim milk, and four agars without skim milk were tested simultaneously on 505 milk samples in a total of ten laboratories. The productivities of the five proposed new media were compared with that of the Standard Medium, with due consideration being given to effects of size of counts, differences among laboratories, and dilutions used. Agars without skim milk can be prepared which possess more desirable attributes than, and colony counts at least as great as, the Standard medium.

LAST year the Committee on Applied Laboratory Methods of the INTERNATIONAL ASSOCIATION OF MILK AND FOOD SANITARIANS, INC. arranged for twelve laboratories to cooperate in a study of plating agars proposed as substitutes for the present American Public Health Association Standard Methods agar containing skim milk. Since the

* Presented at the Thirty-seventh Annual Meeting of the INTERNATIONAL ASSOCIATION OF MILK AND FOOD SANITARIANS, INC., Atlantic City, New Jersey, October 15, 1950.

† The authors wish to express their appreciation to Mr. Louis Pincus and Mr. Arthur S. Kraus, of the New York City Health Department, for their assistance with the statistical work; and to the following laboratories for their cooperation in providing the data: Bureau of Laboratories, State Department of Health, Hartford, Connecticut; Bureau of Laboratories, State Board of Health, Jacksonville, Florida; Division of Laboratories, State Department of Public Health, Chicago, Illinois; Caddo Branch Laboratory, Division of Laboratories, State Department of Health, Shreveport, Louisiana; Central Laboratory, Division of Laboratories, State Department of Health, New Orleans, Louisiana; Quality Control Committee Laboratory, St. Paul, Minnesota; Laboratory Section, Division of Health, Department of Public Welfare, St. Louis, Missouri; National Dairy Research Laboratories, Inc., Oakdale, Long Island, New York; Department of Health, Steubenville, Ohio; Public Health Laboratory, Department of Public Health, Oak Ridge, Tennessee; Bureau of Laboratories, State Department of Health, Austin, Texas; Hygienic Laboratory Division, State Department of Health, Charleston, West Virginia.

addition of skim milk has in some instances resulted in troublesome precipitates, many laboratory workers have expressed their desire for a substitute free from this ingredient. Such a substitute should possess sufficient nutritive qualities to yield plate counts of milk samples approximately equivalent to those now obtained with Standard Methods agar, so that present grade standards need not be changed.

PLAN OF STUDY

Through the cooperation of two manufacturers of dehydrated media, the present Standard Methods Tryptone Glucose Extract Milk Agar (Medium #1) and a substitute containing skim milk (Medium #2) were prepared, and in addition each manufacturer prepared in dehydrated form two agars to be used without the addition of skim milk. ‡ Media 3 and 4 were devised and recommended by Dr. Leon Buchbinder *et al.*¹; Media 5 and 6 by the two companies.

These six agars were distributed to the laboratories agreeing to participate. Each laboratory was requested to test the media on 25 samples each of raw and pasteurized milk. Each milk sample was to be tested with all media simultaneously in at least two decimal dilutions, with two plates for each dilution. All plates were to be incubated at 35° C and the reports to show the

‡ Medium #3 contained yeast extract 0.35%, tryptone 0.5%, dextrose 0.1%; Medium #4, phytone 1.0%, polypeptone 0.5%, dextrose 0.1%, sodium sulfite 0.04%, cystine 0.04%; Medium #5, yeast extract 0.5%, proteose peptone #3, 0.5%, casamino acids, technical 0.5%, dextrose 0.1%; Medium #6, trypticase 1.5%, phytone 0.5%, dextrose 0.5%, sodium chloride 0.4%, sodium citrate 0.1%, sodium sulfite 0.02%, cystine 0.02%.

results of each individual plate counted.

Before the productivity of the media was compared, the data were analyzed to determine whether all the results from all the laboratories could properly be pooled. First an investigation was made to determine whether the estimates of counts at different dilutions were interchangeable. Since this analysis demonstrated the existence of a highly significant difference between such estimates, different dilutions of the same sample thereafter were treated as different samples. The word "sample" is used hereafter to refer to one dilution of a milk sample, unless otherwise indicated.

High and low counts (actual, not estimated) were studied separately because of the wide range of acceptable counts (10 to 1,000) and the possibility that size of count might have an appreciable effect on the results. The dividing point was chosen so that the number of high and low samples were approximately equal. Samples whose average counts were less than 70 were called low samples; the rest were considered high.

The laboratories were then tested for homogeneity with respect to the amount of variation occurring between counts of duplicate plates. Significant differences among the laboratories were found. Nevertheless it was decided that the primary

TABLE 1
NUMBER OF SAMPLES REPORTED BY LABORATORIES AND USED IN STUDY, BY LABORATORY

Laboratory	Raw milk				Pasteurized milk			
	Number reported		Number used		Number reported		Number used	
	Milk samples	Samples*	Milk samples	Samples*	Milk samples	Samples*	Milk samples	Samples*
A	25	50	20	26	25	50	18	21
B	25	25	24	23	25	25	22	22
C	25	39	23	27	25	58	24	38
D	25	25	22	22	25	25	20	20
E	29	58	22	30	29	58	22	33
F	26	51	22	30	25	50	21	28
G	26	52	22	27	27	54	20	29
H	28	34	25	25	24	47	16	17
I	27	54	19	25	25	50	21	33
J	27	54	19	25	31	62	23	29
Total	236	388	199	235	261	479	207	270

* A sample consists of twelve counts (duplicate plates for six media) at one dilution.

purpose of the analysis, a comparison of the media, would best be served by combining the data from all the laboratories. It should not be forgotten, however, that deviations from the general pattern are to be expected when data from single laboratories are studied.

After the preliminary investigations were completed, the pattern for the analysis of the comparative productivity of the six media emerged. Different dilutions were treated as different samples; high and low counts were considered separately; and results from all the laboratories were pooled.

DATA

Statistical analyses were limited to the data obtained by the first ten laboratories reporting, because of a time limitation. Nine laboratories used samples of both raw and pasteurized milk, while one used pasteurized milk only. Table 1 lists the number of samples reported by each laboratory, and the number used in the analysis. There were a total of 113 raw and 168 pasteurized samples omitted from the analysis because of incompleteness: that is, colonies on some of the plates were too numerous to count, spreaders were present, etc.; and 40 raw and 41 pasteurized samples were omitted because the average count was less than 10 or more than 1,000. Since the total number of samples reported on were 388 and 479 for raw and pasteurized respectively, there remained totals of 235 and 270 samples to be analyzed. Each of these

samples furnished twelve counts (duplicate plates for six media) which averaged between 10 and 1,000.

EFFECT OF DILUTION ON ESTIMATED COUNT

Two kinds of analysis were used. An exact method, analysis of variance, was applied to the data from laboratories which had ten or more milk samples with duplicate plates for each of the six media at two successive decimal dilutions. In addition a cruder method, described below, was applied in all cases where two dilutions were used.

For the work with dilutions, all the counts were multiplied, when necessary, by the power of ten necessary to make them equivalent to dilutions of 1:100 for pasteurized milk, and 1:1,000 for raw milk.

The analysis of variance provides an exact method of determining whether the difference in the average estimated counts based on two dilutions may be attributed to chance. A comparison was made between variation due to difference in dilution, and variation between duplicate counts, the latter being attributed to chance. If the former is significantly higher than the latter, then the dilution used most probably has a real effect on the estimated count. Table 2 summarizes this comparison of dilutions. The geometric mean of the counts resulting from the higher dilution ranged from 13 to 49 percent higher than the averages from the lower dilution for the same milk samples. The difference between dilutions was highly significant in each group of samples.

The results of the cruder analysis are given in Table 3. The unit used was a set of four counts—duplicate counts at each of two successive dilutions with the same medium. The number and percentage of times the higher dilution yielded a higher average count is given, together with the probability that this percentage could have differed from 50 percent by chance. Again the results were highly significant.

This effect of dilution on estimated count has been noted by other workers. Wilson² showed that the discrepancy between the results from two dilutions increases with the number of colonies counted. James and Sutherland³ suggest that corrections be applied to make the counts from different dilutions interchangeable.

TABLE 2

EFFECT OF DILUTION ON ESTIMATED COUNT: GEOMETRIC AVERAGES OF COUNTS, BY DILUTION, AND ANALYSIS OF VARIANCE OF DILUTIONS

Laboratory and milk product*	Geometric mean of counts			Analysis of variance			
	Lower dil.	Higher dil.	Percent higher of lower dil.	Between dil.		Between dupl.	
				Mean sq. (in logs)	D.F.	Mean sq. (in logs)	D.F.
Raw milk:							
Lab. E	25.9	36.3	140.3	1.2898 †	1	0.0077	120
Lab. F	97.5	145.5	149.2	2.3426 †	1	0.0116	156
Past. milk:							
Lab. C	108.1	134.3	124.2	0.3345 †	1	0.0067	120
Lab. E	332.7	408.4	122.8	0.6275 †	1	0.0037	156
Lab. G	176.6	199.5	113.0	0.3126 †	1	0.0070	216
Lab. I	134.3	186.2	138.6	1.8130 †	1	0.0041	180

* Laboratories which had ten or more milk samples with 12 counts at each of two successive decimal dilutions.
† Probability less than 0.01, indicating high degree of significance.

TABLE 3

EFFECT OF DILUTION ON ESTIMATED COUNT: NUMBER AND PERCENTAGE OF HIGHER ESTIMATED COUNTS WITH HIGHER DILUTION, BY LABORATORY AND MILK PRODUCT

Laboratory and milk product	No. of units*	Higher estimated counts with higher dilutions	
		Number	Percent
Raw milk:			
Lab. A	53	43	81 †
Lab. C	29	28	97 †
Lab. E	89	82	92 †
Lab. F	97	76	78 †
Lab. G	48	40	83 †
Lab. H	6	5	83 †
Lab. J	66	48	73 †
Past. milk:			
Lab. A	65	50	77 †
Lab. C	124	96	77 †
Lab. E	110	89	81 †
Lab. F	113	84	74 †
Lab. G	131	95	73 †
Lab. H	62	41	66 ‡
Lab. I	124	117	94 †
Lab. J	67	49	73 †
Total	1,184	943	80 †

* Each unit consists of a pair of duplicate plates at two successive decimal dilutions.

† Probability less than 0.01, indicating high degree of significance.

‡ Probability between 0.05 and 0.01, indicating significance.

DIFFERENCES AMONG LABORATORIES

The variation among laboratories is given in Table 4 and shown graphically on Chart 1. The basis for comparison was the variation between counts of duplicate plates. The geometric mean of the higher counts was expressed as a ratio of the geometric mean of the lower counts. This ratio is identical with the geometric mean of the ratios of the higher to the lower counts of the duplicates.

The average ratios ranged from 1.07 to 1.23 for the high count samples; and from 1.11 to 1.45 for low count samples. That is, there was less variability between high count than low count duplicates regardless of whether the milk was raw or pasteurized. There is, of course, nothing new in this finding.

An upper limit was calculated giving the ratio (higher to lower count) below which 95 percent of the ratios for duplicates could be expected to fall. This limit ranged from about 1.28 to 1.76 for high counts; and from 1.37 to 2.75 for low counts.

CHART 1.

VARIABILITY* OF COUNTS BY LABORATORY, BY TYPE OF MILK SAMPLE

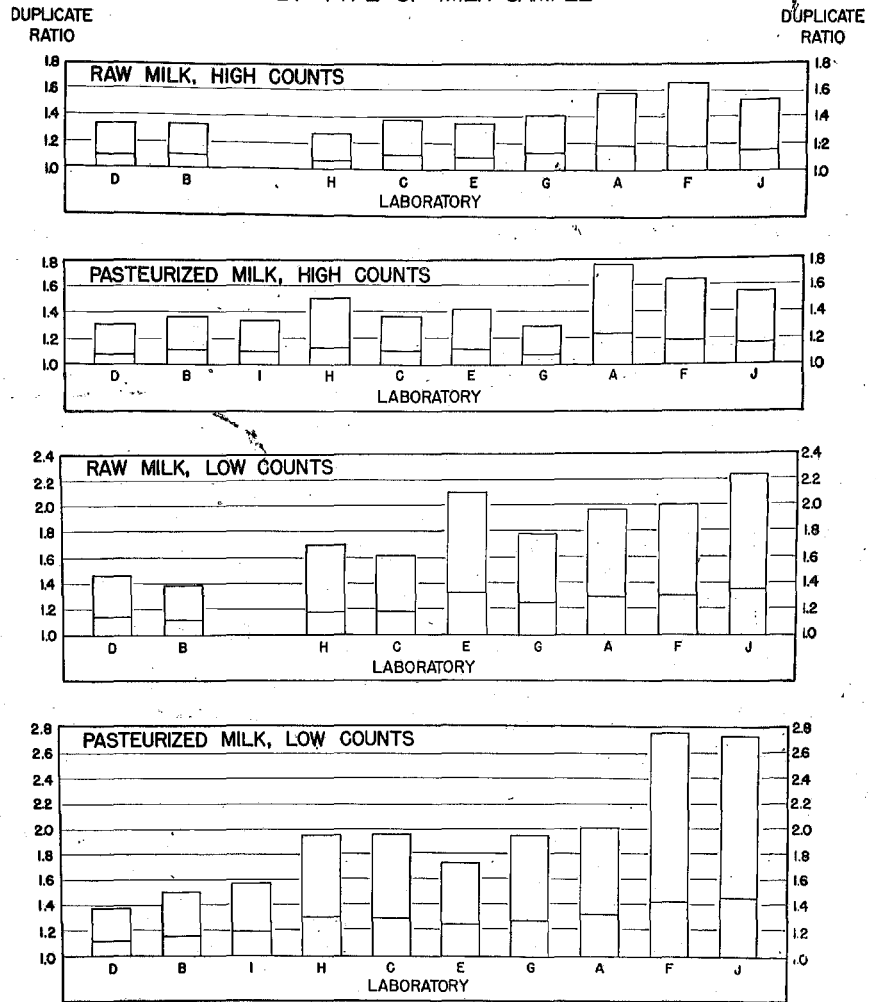

* Variability is measured by duplicate ratios. A duplicate ratio is the ratio of the higher to the lower count of a duplicate pair of plates.

NOTES: "Low count" samples are samples whose average count was not less than 10 or more than 69; "high count" average counts ranged from 70 to 1,000.

The upper limit of each bar is the level below which 95% of the duplicate ratios are estimated to fall.

The horizontal line within each bar is the geometric mean of the duplicate ratios.

In general, laboratories D, B, and I showed least variation; and laboratories A, F, and J, most. E's results varied with the type of sample considered. H, C, and G showed moderate variation.

These comparisons are not intended as a measure of the relative quality of the work of the laboratories. This technic, however, could be used to measure quality, provided that the plates counted were not identifiable as duplicates by the counter.

It is noteworthy that the three laboratories showing least variation

were state health department central or branch laboratories in states where the state health department supervises all local laboratories making official bacteriological analyses of milk. Furthermore, the bacteriologists supervising this activity had attended one of the In-Service Training Courses given in Cincinnati by the Public Health Service Environmental Health Center for bacteriologists primarily concerned with milk and food sanitation. The bacteriologists in the next three laboratories showing moderate variation were city or state health depart-

ment personnel who had attended one of the above In-Service Training Courses.

COMPARISON OF PRODUCTIVITY OF THE MEDIA

Media numbers 2, 3, 4, 5, and 6 were each compared to the present Standard Methods Tryptone Glucose Extract Milk Agar, medium #1. The method used was approximate, but accurate enough for practical purposes.* Essentially, it is approximately equivalent to computing the geometric mean of the ratios (med. #x)/(med. #1) for each type of sample, and testing to see whether that mean is significantly different from one. The probabilities that the observed geometric means of ratios could occur by chance if the true ratio were one, were computed. When such a probability is low, for example less than 0.05, the difference between the two media is said to be significant.

Table 5 lists the geometric means of the media for the various categories of samples. Table 6 expresses the means of media #2 to #6 as percentages of the mean of the standard medium, and gives the ranges of these percentages. The meaning of the range of the observed percentages is somewhat indirect. The true difference between two media cannot be known precisely, and can only be estimated from samples of counts such as the ones studied. However, unless the samples are extremely biased, the observed value can be expected to lie close to the true value. The range used in the table is expected to include the true value 95 percent of the time.

These results are represented graphically in Chart 2. In general, all the media showed greater differences from medium #1 in the low than in the high count samples. The differences were also somewhat greater for raw than for pasteurized milk, except in the case of medium #3.

Medium #4 was the only medium which was significantly different from medium #1 for all the categories of samples. The overall difference was +8.5 percent.

TABLE 4
VARIABILITY OF COUNTS AS MEASURED BY DUPLICATE RATIOS,* BY LABORATORY

	Laboratories									
	D	B	I	H	C	E	G	A	F	J
<i>Raw milk, high counts</i>										
Geom. mean of D.R.'s †	1.09	1.10	1.07	1.11	1.09	1.12	1.18	1.18	1.15
95%-point ‡	1.33	1.33	1.28	1.38	1.35	1.41	1.58	1.65	1.53
Number	84	66	114	84	108	96	78	72	66
<i>Pasteurized milk, high counts</i>										
Geom. mean " "	1.08	1.11	1.09	1.13	1.10	1.11	1.07	1.23	1.18	1.16
95%-point ‡	1.31	1.36	1.33	1.51	1.36	1.42	1.29	1.76	1.64	1.55
Number	72	84	78	30	114	108	78	30	84	66
<i>Raw milk, low counts</i>										
Geom. mean " "	1.14	1.11	1.17	1.18	1.32	1.24	1.29	1.30	1.35
95%-point ‡	1.46	1.38	1.69	1.61	2.10	1.77	1.96	2.00	2.23
Number	48	72	36	78	72	66	78	108	84
<i>Pasteurized milk, low counts</i>										
Geom. mean " "	1.11	1.14	1.18	1.29	1.28	1.23	1.26	1.32	1.42	1.45
95%-point ‡	1.37	1.49	1.56	1.94	1.95	1.72	1.94	2.00	2.75	2.72
Number	48	48	120	72	114	90	96	96	84	108

* A duplicate ratio is the ratio of the higher to the lower count of a duplicate pair of plates.
† D.R.'s are duplicate ratios.
‡ The 95%-point is the level below which 95% of the duplicate ratios are estimated to fall.

TABLE 5
PRODUCTIVITY OF MEDIA: GEOMETRIC MEANS OF PLATE COUNTS

Medium	Geometric means					
	Raw milk samples			Pasteurized milk samples		
	All	Low	High	All	Low	High
#1	77.1	28.2	178.4	59.1	25.8	156.7
#2	80.5	30.5	181.3	58.7	25.7	155.2
#3	80.8	30.1	184.6	66.6	29.7	172.2
#4	84.2	32.0	188.9	63.7	27.9	168.1
#5	84.5	31.6	192.0	62.2	27.3	163.8
#6	78.3	29.7	176.1	50.6	21.6	137.3
No. of samples	235	107	128	270	146	124

TABLE 6
PRODUCTIVITY OF FIVE PLATING MEDIA COMPARED TO THAT OF STANDARD MEDIUM, BY TYPE OF SAMPLE

Medium	Samples	Raw milk		Pasteurized milk	
		Percent of standard medium	Range of percent	Percent of standard medium	Range of percent
		#2	All	104.4*	101.0-107.9
	Low	107.8*	101.4-114.6	99.8	93.5-106.5
	High	101.6	98.4-105.0	99.1	95.0-103.4
#3	All	104.8*	100.6-109.2	112.8†	108.3-117.5
	Low	106.4	98.9-114.5	115.2†	108.6-122.2
	High	103.5	98.9-108.3	109.9†	104.1-116.1
#4	All	109.2†	105.0-113.6	107.8†	102.9-113.0
	Low	113.3†	105.5-121.5	108.2*	100.9-116.0
	High	105.9†	101.6-110.3	107.3*	100.9-114.1
#5	All	109.7†	105.2-114.4	105.2*	101.0-109.6
	Low	112.0†	103.7-121.0	105.9	99.5-112.7
	High	107.6†	103.0-112.4	104.5	99.2-110.0
#6	All	101.6	97.9-105.5	85.6†	81.3-90.1
	Low	105.6	99.0-112.7	83.9†	78.0-90.3
	High	98.7	94.7-102.8	87.6†	81.6-94.1
No. of samples	All		235		270
	Low		107		146
	High		128		124

* This method is described in detail in Reference 1.

* Probability between .05 and .01, indicating significance.
† Probability less than .01, indicating high degree of significance.

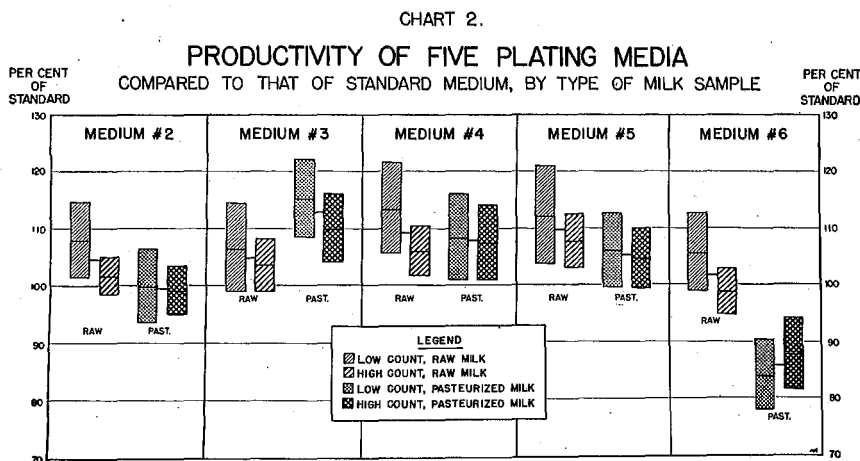

NOTES: "Low count" samples are samples whose average count was not less than 10 or more than 69; "high count" average counts ranged from 70 to 1000.

The center line of each bar is the geometric mean of medium #X expressed as a percentage of the geometric mean of the standard medium for the same samples. The line connecting two bars is the same kind of percentage for both types of samples combined.

The length of each bar represents the range within which the true value of the percentage lies 95 percent of the time. If this range does not include 100 percent, there is a significant difference from the standard medium.

Media #3 and #5 are, on the whole, significantly different from medium #1, although the significance is questionable for some categories. The overall differences were +9.0 percent and +7.3 percent respectively.

Medium #2 (containing skim milk) was not significantly different from medium #1.

Medium #6 was significantly lower than medium #1 for pasteurized milk, and approximately equal to it for raw milk.

APPEARANCE OF AGAR

In addition to the plate counts reported, several of the participating laboratories made detailed comments based on their experience with the agars, particularly as to relative ease of counting, clarity of media, contrast and size of colonies, frequency of spreaders, etc. Such characteristics might well be an important consideration affecting the choice of media which yield comparable numerical counts. Several laboratories reported clearer background and

greater ease of counting, as well as greater frequency of larger colonies, with agars 3, 4, 5, and 6; i.e., the agars which did not contain milk.

CONCLUSIONS

1. Estimates of bacterial plate counts made at different dilutions are not interchangeable.

2. Laboratories adhering closely to Standard Methods requirements produce more reliable plate counts than other laboratories.

3. Of the five proposed new plating media studied, the one with skim milk was as productive as the present Standard medium, and the productivities of the four without skim milk ranged from somewhat less than, to about 8 percent greater than, that of the Standard medium.

4. Laboratories making the tests reported that the agars without skim milk were superior, to those with skim milk with respect to freedom from precipitates, clearness of background, and size of colonies.

REFERENCES

1. Buchbinder, L., Baris, Y., Alf, E., Reynolds, E., Dillon, E., and Pessin, V., Strauss, A., and Pincus, L. Studies to Formulate New Media for the Standard Plate Count of Dairy Products. *Pub. Health Reports*, 66:327-340 (1951).
2. Wilson, G. S. The Bacteriological Grading of Milk. *Med. Res. Council Spec. Rep. Ser. #206* (1935), pg. 121.
3. James, N., and Sutherland, M. T. Effect of Numbers of Colonies per Plate on the Estimate of the Bacterial Population of Soil. *Canadian J. Res.*, 18, 347, Sec. C (1940).

Supreme Court Invalidates Restrictive Milk Ordinance

A recent decision of the Supreme Court of the United States, invalidates a provision of the milk control ordinance of Madison, Wisconsin, which restricts the sale of milk not pasteurized within five miles of the city center.

The Supreme Court vacated judgment and remanded to the Supreme Court of Wisconsin the case of the Dean Milk Company of Illinois versus the City of Madison. In so doing, the Supreme Court invalidated a section of the Madison ordinance which makes it unlawful to sell milk as pasteurized unless it is

processed and bottled at an approved pasteurization plant within five miles from the central square of the city.

The Court said the ordinance "in practical effect excludes from distribution in Madison wholesome milk produced and pasteurized in Illinois."

"In thus erecting an economic barrier protecting a major local industry against competition from without the State, Madison plainly discriminates against interstate commerce," the Court said.

The case was remanded to the

Wisconsin Supreme Court because it had not passed on another pertinent section of the Madison ordinance, a section which relieves local authorities from any statutory duty to inspect farms located beyond 25 miles of the center of the city.

The Supreme Court of the United States remanded the case to the State court for a determination on the validity of this section, "not inconsistent with the principles announced" with respect to the 5-mile limitation.

(Continued on page 123)

PEROXIDASE INACTIVATION IN PROCESSED CUCUMBER PICKLES^{1,2}

E. A. NEBESKY, W. B. ESSELEN, JR., AND C. R. FELLERS

*Department of Food Technology
University of Massachusetts
Amherst, Massachusetts*



Dr. Edward A. Nebesky received his B.S. (1943), M.S. (1948), and Ph.D. (1950) in food technology at the University of Massachusetts. His major field of interest was concerned with a study of enzyme systems in acid foods. At present he is teaching food technology and continuing research investigations in this subject at the University of Massachusetts. During World War II he served as an officer in the United States Army (Mechanized Cavalry) for three and one-half years and is now a member of a Reserve Research and Development Unit.

In the processing of cucumber pickle products such as Kosher Style dill and Processed dill pickles attention should also be given to the destruction of enzymes present in the product, as well as potential spoilage microorganisms, which may lead to the development of undesirable changes in color, flavor, and aroma during storage.

It is common knowledge that enzymes, unless effectively inactivated during processing, are responsible for a considerable amount of food spoilage. For example, oxidative enzymes are responsible for destruction of vitamin C in freshly expressed and unheated apple juice and in certain other juices. Enzymes cause undesirable changes in flavors and odors in frozen packs of fruits and vegetables. Proteolytic and related enzymes are frequently encountered in autolytic and putrefactive deterioration during processing of fish and meat products. Many other examples could be given to illustrate the adverse effect of enzymes upon the quality of food products. The problem of maintaining high quality in foods necessitates the destruction of those enzymes which are present and capable of causing deterioration.

The destruction of enzymes may be brought about in several different ways. The use of sulfur dioxide to prevent enzymatic deterioration in various fruits has been recommended.^{1,2,3} Many enzymes are inactivated by the ions of heavy metals,⁴ such as silver, mercury, and copper. Potassium cyanide, fluoride ion, 60 percent alcohol, papain, and trypsin all inhibited the activity of the enzymes of certain grapes.⁵

Low temperature and ice formation have long been known to retard, although they do not inhibit, enzyme activity. The early literature on the influence of low temperature was summarized by Hepburn⁶ and, more recently, by Sizer⁷ who called attention to the fact that enzymes are

not inactivated by storage at temperatures as low as -303° F (-186° C).

Another method for the destruction of enzyme activity involves the use of heat. It is generally known that the velocity of enzyme action is greatly affected by temperature. For most enzymes the optimum temperature lies between $104-122^{\circ}$ F ($40-50^{\circ}$ C). At temperatures below 104° F (40° C) most enzymes are fairly stable, but at temperatures above 122° F (50° C), inactivation is usually rapid. The so-called "inactivation temperature" for enzymes is an indefinite entity, inasmuch as it depends on the pH value of the medium, the percentage of moisture present, the length of the heating period, the length of the period of determination, and many other factors.

THERMAL INACTIVATION OF ENZYME ACTIVITY

Much data has been presented^{8,9,10,11,12,13} concerning thermal destruction of various enzyme systems in acid foods. An enzyme which has been heated just to the point of inactivation has the ability sometimes to regenerate itself in the cold and thus regain its activity.^{14,15,16}

Ball^{17,18} recognized the possibility of applying the procedure for deriving thermal process times for food products, based on destruction of microorganisms, to the thermal destruction of enzymes. Various investigators^{19,20} reported on the heat process requirements of citrus juices necessary to destroy pectinase enzymes. In studies on phosphatase inactivation of milk and dairy products, Sanders and Sager²¹ described a laboratory pasteurizer used for controlling the time-temperature relationship with a high degree of precision. Hollard and Dahlberg,²² Kay and Graham²³ Prucha and Corbett²⁴ have reported on the time-temperature relationships necessary to inactivate the phosphatase enzyme in milk. The results obtained with the above groups dif-

fered considerably. Most of the discrepancies probably could be accounted for by variations in length of time required to heat to and cool from the temperatures at which they were held.²² Lythgoe²⁵ commented that if milk is heated very quickly the time of inactivation of phosphatase may be necessarily longer than if milk is heated more slowly. Other studies have indicated that as the temperature to which milk is heated increases, the cumulative effect of heating to reach the highest temperature becomes progressively more important. Using a heating time of 35-40 seconds, phosphatase was found to be inactivated by an instantaneous exposure at 160° F (71° C).²⁴

Hetrick and Tracy²⁶ in studies on the effect of various rates of heating on the temperature required to inactivate phosphatase, secured data indicating that the mathematical solution is satisfactory for practical use in determining the time and temperature necessary for destruction of phosphatase in milk. It follows that, if the phosphatase test can be applied as a standard for adequate pasteurization in milk, then the mathematical solution can likewise be applied to determine exact processing conditions of time and temperature for other food products based on the destruction of enzyme systems.

¹ Contribution No. 800, Massachusetts Agricultural Experiment Station.

² Presented before Northeast Section, Institute of Food Technologists Meeting, Boston, December 7, 1950.

PEROXIDASE DESTRUCTION

Through the application of the General Method of Process Time Determination^{27, 28} (used for determining processing conditions necessary to sterilize canned foods based on destruction of microorganisms) Kaplan, Esselen, and Fellers²⁹ studied the effect of heating upon the peroxidase and other enzyme systems of canned acid foods in order to determine their fate during processing. By such means the effect of heat preservation upon the enzymes could be observed and studied. Their investigations showed good agreement between calculated processes for destruction of peroxidase and actual processes in the case of pureed foods, indicating that the processing times necessary to destroy the enzyme in canned acid foods at specific temperature could be accurately predicted.

This investigation was concerned with a study to determine whether the processing conditions of time and temperature could be accurately predicted for destruction of peroxidase in solid cucumber pickle packs. In heating food packs in which the product consists of large whole pieces one is confronted with the possibility that the interior of the food material may not reach the low temperatures necessary for enzyme destruction and thereby result in under-processing.

Preliminary studies³⁰ revealed that in the case of Kosher style dill and processed dill pickles the processing conditions, apparently adequate to destroy spoilage microorganisms, were not sufficient to insure complete inactivation of the peroxidase system. Further, it can be assumed that if peroxidase were not destroyed, other enzyme systems might likewise retain their activity during processing and become capable of affecting the quality of such foods. The procedure used in this investigation was similar to those previously described by Nebesky *et al.*³¹ Peroxidase was selected as most suitable enzyme for study because (1) it is one of the most heat-resistant of the enzymes which are normally encountered in fruits and vegetables, (2) its assay is easily, quickly, and accurately carried out, (3) it lends itself well to end-point determinations in heat resistance studies, and (4) its inactivation probably assures the destruction

of other detrimental enzymes which might be present in the raw material and capable of causing deterioration.

The results of this study showed that calculated process times derived by the processing of experimental packs were in close agreement with observed process times, thus indicating the possibility of determining processing conditions necessary for destruction of peroxidase in whole cucumber pickle packs. The general method as applied to this investigation is based on the assumption that the thermal destruction time (TDT) curves for the enzyme are straight lines when plotted on semi-logarithmic paper. Because the thermal destruction time curves of the enzyme under consideration were straight lines when plotted on semi-logarithmic paper, the method is applicable for accurately predicting peroxidase destruction under practical processing conditions. The thermal destruction values of heating to and cooling from the processing temperature were also evaluated, and these values adjusted to the process for peroxidase destruction in the respective packs. Other preliminary studies³¹ have indicated that considerable variation in peroxidase concentration occurs within different lots of the same product and that increasing the concentration of the enzyme increased its thermal stability. Thus, the determination of thermal processes for destruction of enzyme systems in food products must be based on a maximum load or concentration of enzyme. Since such substances as vinegar, salt, and mustard oil are frequently used in the canning and packing of foods, investigations were made to determine the effect of such additions upon the thermal destructive characteristics.

The addition of a 2.5 and 5.0 percent vinegar solution markedly decreased the resistance of the pickle peroxidase to inactivation by heat. The addition of small amounts of salt (2 percent) or mustard oil (10, 25, and 50 ppm) had no effect on the thermal stability of pickle peroxidase. Calculated process times for the above packs were in close agreement with observed process times.

SUMMARY

Processing conditions as used for the destruction or inhibition of microorganisms capable of producing deterioration in a variety of pickle

products were also adequate to insure complete inactivation of the peroxidase system in those foods with the exception of packs of Kosher Style Dill and Processed Dill pickles. Further, peroxidase which was not inactivated in fresh cucumber pickles during processing, was not destroyed during storage for one year.

Whether the amount or type of enzymes present as a result of insufficient processing is harmful to food quality is difficult to predict. However, since previous studies revealed the deteriorative action of a peroxidase preparation on the quality of color, flavor, and aroma of cucumber pickles during storage, it is suggested that attention must also be focused on destruction of the enzymes during the processing of such products.

REFERENCES

1. Cruess, W. V. *Commercial Fruit and Vegetable Products*. Third Edition, McGraw-Hill Book Co., Inc., New York, 1948.
2. Esselen, W. B., Jr., Hart, W. J., Jr., and Fellers, C. R. Further Studies on the Use of Calcium Chloride to Maintain Firmness in Canned and Frozen Apples. *Fruit Prod. J.*, 27, 8-13 (1947).
3. Woodroof, J. G., Shelor, E., Cecil, S. R., and Atkinson, I. S. Preparation of Peaches for Freezing. *Ga. Agr. Exp. Sta. Bul. No. 261*, 70 pp., (1947).
4. Sumner, J. B., and Somers, G. F. *Chemistry and Methods of Enzymes*. Second Edition, Academic Press Inc., New York, 1947.
5. Hussein, A. A., and Cruess, W. V. Properties of the Oxidizing Enzymes of Certain Vinifera Grapes. *Food Research*, 5, 637-648 (1940).
6. Hepburn, J. S. The Behavior of Enzymes at Low Temperature. *Biochem. Bul.*, 4, No. 13, 136-150 (1915).
7. Sizer, I. W. Effect of Temperature on Enzyme Kinetics. *Advances in Enzymology*, 3, 35-62 (1943).
8. Overholser, E. L., and Cruess, W. V. A Study of the Darkening of Apple Tissue. *Univ. of Calif. Agr. Exp. Sta. Tech. Paper*, 7, 40 pp., (1923).
9. Cruess, W. V., Quin, P. J., and Mrak, E. M. Observations on the Browning of Canning Peaches. *Fruit Prod. J.*, 12, 38-41 (1932).
10. Joslyn, M. A., and Marsh, G. L. Some Factors Involved in the Preservation of Orange Juice by Canning. *Ibid.*, 14, 45-49, 56 (1934).
11. Kertesz, Z. I. Pectic Enzymes, III. Heat Inactivation of Tomato Pectin-Methoxylase (pectase). *Food Research*, 4, 113-116 (1939).
12. Strachan, C. C. Factors Influencing Ascorbic Acid Retention in Apple Juice. *Can. Dept. Agr. Tech. Bul. No. 40*, 31 pp., (1942).

(Continued on page 108)

MILK and FOOD SANITATION

THE DIRECT MICROSCOPIC COUNT ON PRESERVED MILK SAMPLES: AN EFFECTIVE MEASURE FOR UNIFORM STATE-WIDE CONTROL*

F. B. CLAIBORNE AND K. E. COX

West Virginia Department of Health, Hygienic Laboratory Division
Charleston 5, W. Va.



Frost Brown Claiborne is Supervisor of the Sanitation Bacteriology unit of the West Virginia State Hygienic Laboratory in Charleston, West Virginia. Born in West Virginia and graduated with a B.S. degree with a major in Bacteriology from the University of Tennessee in 1939. Member of A.P.H.A. and Associate of A.S.P.B.

A survey is presented of the use of preserved milk samples shipped from a state-wide area to a central laboratory for examination. Statistical analysis of comparative results on a large number of samples proved that within 3 days there was no significant change in grade of preserved milk samples from the grade of the identical samples immediately before preservative was added. This method is suggested for uniformity of the laboratory aspects of milk grading programs throughout a large area, and for evaluation of performance of laboratories engaged in this work.

PREVIOUS to January 1950, the direct microscopic count for grading retail raw and producer milk samples was not widely used in West Virginia. Because of the time limit for milk examinations, only the areas within about 50 miles of Charleston could use the services of the State Hygienic Laboratory. In other areas, direct microscopic count examinations were being attempted by sanitarians who were working without proper space or facilities and using time that should have been devoted to field work and inspection. This system caused confusing and often misleading results and led to the development of a program to insure uniformity of sample collection and all phases of laboratory technique for grading purposes throughout the state. This paper is limited to an analysis of results obtained by the use of preservative in milk samples sent in to the central laboratory by sanitarians from all the counties in the state.

It is not the purpose of this paper to discuss the various staining procedures and stains suggested for the improvement of the direct microscopic examination of milk samples. Certain proposed modifications in both method and stains are definitely

deserving of attention and further study. On the strength of studies in our laboratory, as well as those done by Levine and Black,¹ Levine,² and our results in the comparative study conducted last year under the auspices of the United States Public Health Service, the A.W.F. (acid-water-free) stain was selected and used routinely in this survey. We found this stain the simplest to prepare, the most reproducible, most constant in results, and easiest to read. When using the A.W.F. stain for counting milk films on a large volume of approximately 14,000 specimens, there appeared to be no greater difficulty in counting the preserved specimens, received within 3 days after collection, than when counting unpreserved *fresh* samples. Preliminary experiments were carried out on several different concentrations of formaldehyde ranging in strength from 1 drop of 10 percent formalin in 10 ml of milk, to 10 drops of 10 percent formalin in 10 ml of milk. We found in these experiments that milk samples preserved with formaldehyde in strengths above 0.08 percent to 0.09 percent show marked decrease in the direct microscopic count rather rapidly. Milk samples containing 0.08 percent formaldehyde retain approximately the same count by the direct microscopic count technique for at least 3 days, probably even longer. This same concentration was also found to be the most favorable by Levine² in his experimental survey reported December 1949. Milk to which this concentration of formaldehyde has been added shows no tendency to sour unless it is on the point of souring when introduced into the sample vial. Of approximately 12,000 samples, less than 50 were sour on arrival at the laboratory.

PROCEDURE

Sample vials with tight closures, such as the standard rim count vial,

were selected for use. These vials are graduated at the 10 ml mark for the convenience of the collector and the assurance of the examining laboratory. The vials are sterilized. The correct amount, 0.1 ml of 1/5 dilution of commercial formalin solution is added to each one and it is immediately closed tightly. When 10 ml of milk is added to the vial the resulting formaldehyde concentration is 0.08 percent. Vials so prepared may be successfully stored for at least 10 days prior to use without loss of efficiency for preservation of milk samples.

The requirements in the Eighth³ and Ninth⁴ editions of *Standard Methods for the Examination of Dairy Products* for the collection and delivery of milk samples to the laboratory are strictly followed. Upon receipt of samples at the laboratory, 3 days or less after collection, milk films are made, defatted and fixed in strict accordance with *Standard Methods*.⁴ The slides are then stained for 1½ minutes with the A.W.F. stain. The microscopes are standardized to a factor of 600,000, and the number of fields counted is always at least that required in *Standard Methods*. In the experimental comparisons, shown in our tables, these requirements are generally exceeded.

* Presented before the Coordinating Committee on Laboratory Methods of the American Public Health Association at the Seventy-Eighth Annual Meeting in St. Louis, Mo., November 1, 1950.

TABLE 1

EFFECT ON D. M. C. OF 0.08% FORMALDEHYDE CONCENTRATION IN MILK SAMPLES

Untreated Sample Clump Counts: 1 Million-6 Million

Specimen number	Counts in ten thousands				
	Untreated	Formaldehyde added; stained after			
	Stained immediately	1-2 days		3-4 days	
4240	120	1 day count	90	3 day count	84
4245	114	" " "	64	" " "	86
4305	116	" " "	116	" " "	112
4922	234	2 day count	190	4 day count	232
4923	340	" " "	338	" " "	444
4929	172	" " "	144	" " "	112
4930	170	" " "	206	" " "	357
4933	102	" " "	90	" " "	103
4937	118	" " "	112	" " "	114
4939	292	" " "	244	" " "	378
4940	122	" " "	142	" " "	190
4941	254	" " "	244	" " "	328
4942	600	" " "	490	" " "	796
4943	420	" " "	362	" " "	476
4944	480	" " "	384	" " "	364
4946	214	" " "	200	" " "	274
4947	313	" " "	310	" " "	278
4949	122	" " "	132	" " "	124
4952	354	" " "	560	" " "	300
4960	148	" " "	166	" " "	251
a. Mean	240.2		229.2		270.2
b. Std. error of mean	31.5		30.8		39.1
c. Std. error of difference of means			44.1		50.2
d. Actual difference of means			11.0 (0.25 S.E.)		30.0 (0.6 S.E.)

No statistically significant difference between means.

TABLE 2

EFFECT ON D. M. C. OF 0.08% FORMALDEHYDE CONCENTRATION IN MILK SAMPLES

Untreated Sample Clump Counts: 500,000-990,000

Specimen number	Counts in thousands				
	Untreated	Formaldehyde added; stained after			
	Stained immediately	1-2 days		3-4 days	
4241	540	1 day count	340	3 day count	540
4243	540	" " "	500	" " "	400
4281	780	" " "	940	" " "	960
4282	780	" " "	740	" " "	600
4343	500	" " "	620	" " "	500
4913	500	2 day count	500	4 day count	460
4925	880	" " "	920	" " "	500
4935	640	" " "	520	" " "	660
4936	580	" " "	560	" " "	620
4954	640	" " "	770	" " "	640
R.C.P.	500			" " "	460
56W	580			" " "	600
a. Mean M_1 (10 spec. — 638.			M_2 641		
(12 spec. — 621.7					M_3 578.3
b. Std. error (10 spec. — 42.0			62.0		
of mean (12 spec. — 36.7					41.8
c. Std. error of difference of means			74.9		55.6
d. Actual difference of means			3.0 (0.04 S.E.)		43.4 (0.8 S.E.)

No statistically significant difference between means.

RESULTS AND DISCUSSION

Tables 1 through 5 summarize the results obtained on *unpreserved* milk samples (refrigerated, brought promptly to the laboratory and examined immediately) versus results on the same samples *preserved* as soon as the immediate films were made, and re-examined after standing at room temperature for 1, 2, 3, and 4 days. These tables show comparative counts on 134 samples done in triplicate with clump counts ranging from 10,000 organisms per ml to several million organisms per ml. Much additional data were obtained which are not included in this paper but which support the conclusions. We compared the results statistically, and believe there is no significant difference between the results on the preserved samples as opposed to the unpreserved samples. Two samples changed grade out of 202 samples compared for this study. One additional "border line" sample showed a slightly reduced count after 3 days. These results seem to be well within the limit of experimental error. Because of the small amount of milk used in preparing a direct microscopic count slide, and the need for a different sample shaking operation before each transfer, the same sample of milk will show a variation in count, even though preserved, when slides are made at intervals over periods of several days. Also, with certain types and numbers of organisms the *same film* repeatedly counted by one or more people will often show variations of the same order as those herein described.

The Sanitary Engineering Division of the West Virginia State Health Department states that on more than 12,000 samples, which we have examined by this method to date, the procedure has proved to be a valuable tool in securing dairy farm improvements, and in most instances has correlated well with sanitary inspections.

CONCLUSIONS

We feel that with 0.08 percent formaldehyde concentration in 10 ml of milk, the following conclusions can safely be made:

1. A milk showing a low count (10,000 to 120,000 per ml), will not increase significantly over a

TABLE 3

EFFECT ON D. M. C. OF 0.08% FORMALDEHYDE CONCENTRATION IN MILK SAMPLES

Untreated Sample Clump Counts: 210,000-490,000

Counts in thousands

Specimen number	Untreated		Formaldehyde added; stained after		
	Stained immediately		1-2 days		3-4 days
4238	480	1 day count	600	3 day count	400
4247	260	" " "	260	" " "	220
4251	540	" " "	300	" " "	* 146
4256	370	" " "	550	" " "	300
4278	330	" " "	420	" " "	330
4287	340	" " "	420	" " "	340
4289	300	" " "	400	" " "	360
4297	300	" " "	460	" " "	240
4298	400	" " "	360	" " "	220
4310	460	" " "	500	" " "	380
4323	240	" " "	220	" " "	240
4325	270	" " "	200	" " "	140
4326	280	" " "	260	" " "	240
4348	320	" " "	400	" " "	250
4911	260	2 day count	220	4 day count	230
4912	420	" " "	500	" " "	300
4921	280	" " "	240	" " "	260
4924	320	" " "	300	" " "	320
4927	300	" " "	260	" " "	360
4931	280	" " "	290	" " "	260
4950	490	" " "	700	" " "	360
4957	420	" " "	400	" " "	320
4961	350	" " "	440	" " "	370
4963	380	" " "	420	" " "	560
a. Mean	349.58		380.0		297.75
b. Std. error of mean	16.9		26.6		18.4
c. Std. error of difference of means			31.5		25.0
d. Actual difference of means			30.4 (0.96 S.E.)		51.8 (2.07 S.E.)

Probable statistical significance: Difference between means due to chance.

* Slide very difficult to read.

TABLE 4

EFFECT ON D. M. C. OF 0.08% FORMALDEHYDE CONCENTRATION IN MILK SAMPLES

Untreated Sample Clump Counts: 110,000-200,000

Counts in thousands

Specimen number	Untreated		Formaldehyde added; stained after		
	Stained immediately		1-2 days		3-4 days
4244	140	1 day count	140	3 day count	120
4246	120	" " "	140	" " "	140
4257	160	" " "	180	" " "	80
4269	200	" " "	100	" " "	100
4273	160	" " "	120	" " "	140
4279	140	" " "	100	" " "	80
4304	120	" " "	80	" " "	120
4311	120	" " "	150	" " "	100
4312	140	" " "	110	" " "	30
4321	160	" " "	210	" " "	180
4341	120	" " "	120	" " "	70
4910	140	2 day count	200	4 day count	140
4918	180	" " "	140	" " "	100
4926	200	" " "	160	" " "	160
4958	180	" " "	140	" " "	120
a. Mean	152.0		139.3		112.0
b. Std. error of mean	7.2		9.5		9.84
c. Std. error of difference of means			11.9		12.2
d. Actual difference of means			12.7 (1.06 S.E.)		40.0 (3.27 S.E.)

Statistical significance:

Difference of Mean₁ and Mean₂ due to chance. Difference of Mean₁ and Mean₃ is 0.27 S.E. greater than accepted deviation limit for chance.

period of 1-3 days; a high count (500,000 to over 1,000,000 per ml), will not decrease significantly over a period of 1-3 days; a "border line" count (180,000 to 280,000 per ml), will not change significantly within 3 days but may tend to decrease thereafter.

2. The use of preserved milk samples, using 0.08 percent formaldehyde concentration, if examination is carried out within 3 days after collection, should be a successful procedure for:

A. The grading of milk samples collected from a wide area, submitted by mail unrefrigerated to a central laboratory.

B. The evaluation of performance and comparative results of one or more laboratories at a distance from each other, on identical specimens of milk. It could be a valuable procedure for maintaining accuracy in branch laboratories or in the approval of any laboratory engaged in this work.

3. This method has operated successfully in West Virginia in a control program on the examination of approximately 12,000 specimens received in all seasons from all points of the state even as far distant as 300 miles, with 3 days being the maximum transportation time.

REFERENCES

1. Levine, B. S., and Black, L. A. Comparative Analysis of the Standard Methods Methylene Blue Stain and Advantages of the Polychrome and Acid-and-Water-Free Stains in the Direct Microscopic Examination of Milk. *Amer. J. Pub. Health* 39, 1110-1119 (1949).

2. Levine, B. S. The Effect of Formaldehyde on the Direct Microscopic Count of Raw Milk. *Pub. Health Rep.* 65, 931-938 (1950).

3. Standard Methods for the Examination of Dairy Products. (8th Edition) American Public Health Association, 1941.

4. *Ibid.*, 1948.

ACKNOWLEDGMENTS:

We are indebted to Mr. Guido Iannarelli, Principal Bacteriologist, and to Miss Betholene Love, Senior Bacteriologist, both staff members of this Laboratory, for their interest and aid in the statistical computations. Also, to Mr. W. G. Wiles, Jr., and certain other staff assistants for their aid in examining many of the samples reported.

TABLE 5
EFFECT ON D. M. C. OF 0.08% FORMALDEHYDE CONCENTRATION IN MILK SAMPLES
Untreated Sample Clump Counts: 10,000-100,000

Specimen number	Counts in thousands		
	Untreated	Formaldehyde added; stained after	
		Stained immediately	1 day
4231	40	60	40
4232	60	40	40
4233	20	20	20
4235	60	100	140
4236	20	40	40
4237	40	60	40
4239	60	100	60
4242	100	160	100
4248	100	80	120
4249	60	80	20
4250	60	20	80
4253	100	93	60
4255	60	40	20
4258	40	20	20
4259	40	60	60
4261	80	20	20
4262	60	60	20
4263	20	20	20
4264	70	80	80
4265	80	100	100
4267	40	40	20
4268	100	80	80
4270	40	10	20
4271	20	20	60
4272	40	60	80
4274	20	40	20
4275	20	20	10
4276	20	20	20
4277	20	40	40
4280	80	20	60
4283	100	100	70
4284	100	100	30
4285	20	20	20
4288	100	80	100
4290	60	40	60
4291	40	20	20
4294	20	20	60
4295	20	20	60
4299	90	100	60
4300	20	20	20
a. Mean	53.5	53.07	50.25
b. Std. error of mean	4.67	5.56	5.08
c. Std. error of difference of means		7.26	6.9
d. Actual difference of means		0.43 (0.06 S.E.)	3.25 (0.47 S.E.)

No statistically significant difference between means.

Peroxidase Inactivation of Pickles

(Continued from page 104)

13. Woodroof, J. G. and Atkinson, I. S. Blueberries for Freezing Improved by Blanching. *Refrig. Eng.*, 48, 275-278, 314 (1944).

14. Hand, D. B. Peroxidase Comparison with Iron-Prophyrin Catalysts. *Ergeb. der Enzymforschung*, 2, 272-279 (1933).

15. Schwimmer, S. Regeneration of Heat-Inactivated Peroxidase. *J. Biol. Chem.*, 154, 487-495 (1944).

16. Reddi, R. R., Esselen, W. B., Jr., and Fellers, C. R. Peroxidase Activity of Apple Tissue. *Food Technol.*, 4, 63-68 (1950).

17. Ball, C. O. Short-Time Pasteurization of Milk. *Ind. Eng. Chem.*, 35, 71-84 (1943).

18. Ball, C. O. Mathematics and Experiments in Food Technology. *Food Technol.*, 2, 55-63 (1948).

19. Parks, C. T. Prevention of Curd in Grapefruit Juice. *Canner*, 90, (12), 71-72 (1940).

20. Joslyn, M. A., and Sedky, A. Effect of Heating on the Clearing of Citrus Juices. *Food Research*, 5, 223-232 (1940).

21. Sanders, C. P., and Sager, V. S. Heat Inactivation of Milk Phosphatase in Dairy Products. *J. Dairy Sci.*, 31, 845-857 (1948).

22. Hollard, R. F., and Dahlberg, A. C. The Effect of Time and Temperature of Pasteurization Upon Some of the Properties and Constituents of Milk. *New York Exp. Sta. Tech. Bul. No. 254* (1940).

23. Kay, H. D., and Graham, W. R., Jr. Phosphorus Compounds of Milk. *J. Dairy Research*, 5, 63-74 (1933).

24. Prucha, M. J. and Corbatt, W. J. Time Required for Destruction of Bacteria at Different Temperatures of Pasteurization. *J. Milk. Technol.*, 3, 269-273 (1940).

25. Lethgoe, H. C. A Phosphatase Test as Used by the Mass. Dept. of Pub. Health for Law Enforcement Purposes. *J. Dairy Sci.*, 25, 961-965 (1942).

26. Hetrick, J. H., and Tracy, P. H. Effect of High Temperature Short-Time Heat Treatments on Some Properties of Milk. I. Inactivation of the Phosphatase Enzyme. *Ibid.* 31, 867-879 (1948).

27. Bigelow, W. D., Bohart, G. S., Richardson, A. C., and Ball, C. O. Heat Penetration in Processed Canned Foods. *Nat. Canners' Assoc. Bul. No. 16-L*, (1920).

28. Ball, C. O. Mathematical Solution of Problems on Thermal Processing of Canned Foods. Univ. of Calif. *Publications in Pub. Health*, 1, 15-245 (1928).

29. Kaplan, A. M., Esselen, W. B., Jr., and Fellers, C. R. Enzyme Systems of Canned Acid Foods. Effect of Processing Conditions of Time and Temperature. *Ind. Eng. Chem.*, 41, 2017-2020 (1949).

30. Nebesky, E. A., Esselen, W. B., Jr., and Fellers, C. R. Studies on the Peroxidase in Pickles and Pears. *Food Technol.*, 5, (1951).

31. Nebesky, E. A., Esselen, W. B., Jr., Kaplan, A. M., and Fellers, C. R. Thermal Destruction and Stability of Peroxidase in Acid Foods. *Food Research*, 15, 114-124 (1950).

THE RING TEST FOR BRUCellosis IN HERD MANAGEMENT*

JOHN S. BRYAN

Laboratory Director, Walker-Gordon Laboratory Company, Plainsboro, N. J.



Mr. J. S. Bryan has been Director of Technical Control for the Walker-Gordon Laboratory Company, Plainsboro, New Jersey, since 1944. He received his B.S. degree from the Pennsylvania State College and has always been active in milk sanitation and health educational work. Author and co-author of articles dealing with various problems in dairy technology.

The paper is in the form of a resume and progress report. It was observed that cows once shedding the agglutinins in their milk continued to do so in each succeeding lactation. Findings by the blood test and ring test were studied comparatively. Our impressions are that cows strongly positive by blood test are almost invariably also positive by ring test; but those strongly positive by ring test are not always positive by blood test. Animals vaccinated as calves, classed as blood suspects, very seldom show rise in blood titer and seldom give positive ring tests on their milk. Indications are that the ring test, in numerous cases, will locate animals before their blood titers go up. The ring test can serve as an adjunct to the blood test, but will probably never replace it.

THIS paper should be considered as a resume and progress report in the application of the ring test in herds that are (1) officially accredited for the blood test, (2) clean herds that are not officially accredited, and (3) herds with a low degree of infection. It does not include herds that have never been blood tested, but it does

include herds where calf-hood vaccination has been practiced over a period of years.

TEST ON HERD

The blood test results referred to in this report are official results as reported by the State-Federal Bureau of Animal Industry Laboratory, Trenton, N. J. The ring test was performed by placing one milliliter of milk in a small test tube, adding a drop of stained antigen mixing the samples, then placing the tubes in a 35° C incubator for thirty (30) minutes, and then reading.

The observations made and results obtained have been accumulated over a period of three and one half years.

Two thousand one hundred and eighty (2180) lactating animals, in twenty-two herds were officially blood tested. Six hundred and seventy or about 31 percent of the 2180 head were calf-hood vaccinated. Results of this blood test were as follows: positive 3, suspects 47, negative 2130.

Table 1 gives the results obtained by running the ring test on the milk from the 2180 head.

It has been our observation that most of the non-vaccinated cows classed as suspects have a stronger blood titer as their gestation period progresses, occasionally going positive at calving time. These same suspects, as a rule, do not have a positive ring test. On the other hand, most calf-hood vaccinates classed as suspects, remaining in the herd, very seldom show a rise in blood titer, often going negative and very seldom giving positive ring tests on the milk.

Six months later, 15 of the 22 herds were again officially blood tested, 1647 lactating animals being represented in this survey. The milk from these animals was checked, using the ring test, either two days before or three days after bleeding.

Following are the results of this blood test: no reactors, 26 suspects, and 1621 negative.

Table 2 gives a breakdown of the blood suspects and negative cows, noting the number of vaccinated and non-vaccinated animals, cows having had blood histories as suspects and the ring test reactions of the respective groups.

While making this study, we observed that cows once shedding the agglutinins in their milk continued to do so in each succeeding lactation. It was also noted that a positive ring test is usually obtained in all four quarters, however, there are several cows in these herds that are negative

* Presented at the Thirty-seventh Annual Meeting of the INTERNATIONAL ASSOCIATION OF MILK AND FOOD SANITARIANS, INC., Atlantic City, N. J., October 13-16, 1950.

TABLE 1

2180 Lactating Animals (31% or 670 Calf Vac.)	47 Suspects (Blood) (2 Pos. Ring)	40 Calf Vac.	1 Pos. Ring
			39 Neg. Ring
		7 Non-Vac.	1 Pos. Ring
3 Positive (Blood)	1 Calf Vac.	Pos. Ring	
	2 Non-Vac.	1 Pos. Ring 1 Neg. Ring	
2130 Negative (Blood) (20 Pos. Ring)	3 Calf Vac.	20 Pos. Ring	
	17 Non-Vac.		
	660 Calf. Vac.	2110 Neg. Ring	
1450 Non-Vac.			

TABLE 2

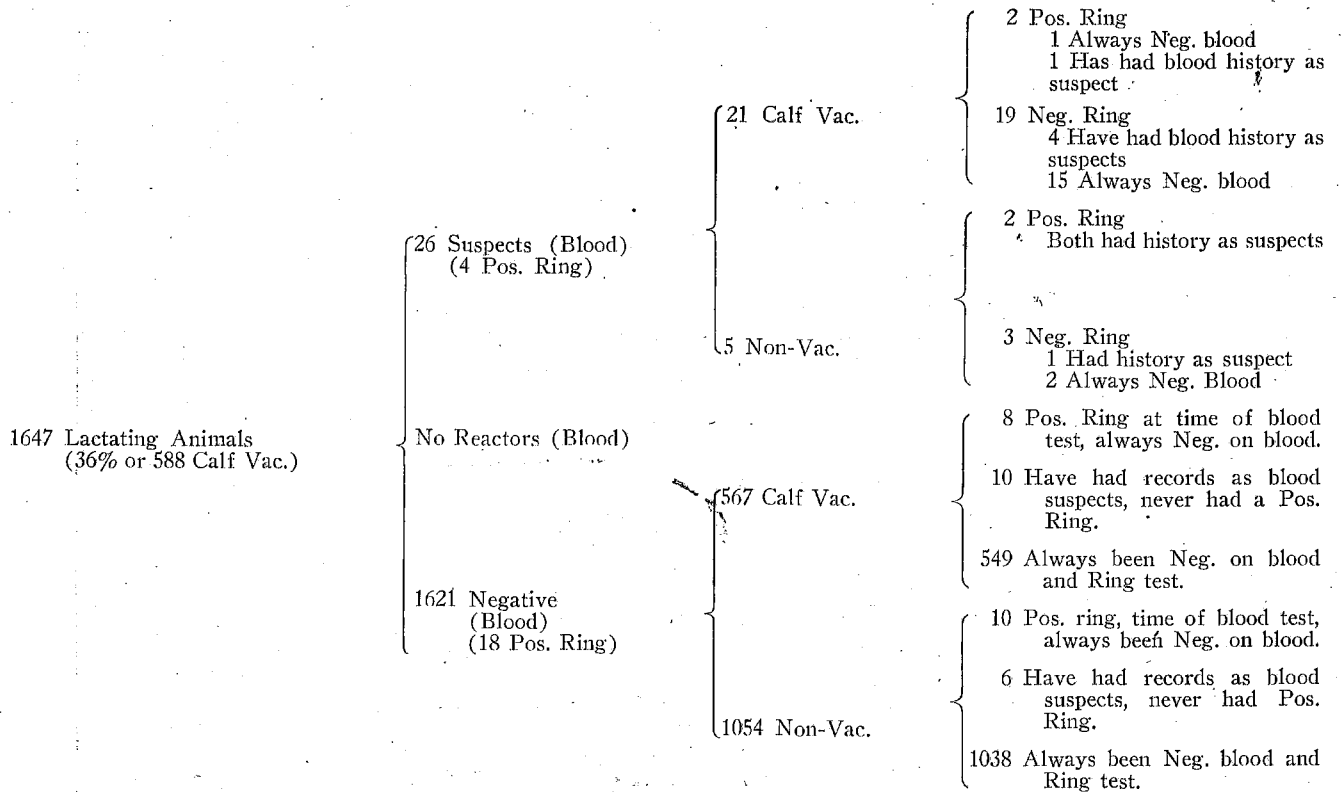

to the ring test in either 1-2-or 3 quarters. The positive quarters remaining positive on each succeeding test, occasionally the negative quarters going positive and remaining positive.

Since using the ring test, we have made 8750 tests this includes the tests reported in tables 1 and 2. Out of the 8750 tests run, the milk from 129 animals was found to give a positive ring reaction; 51 of the 129 head (reacting to the ring test) have had a blood titer at some time or other; 47 of these 129 head have always been negative on the blood and are still negative; and 31 head were disposed of for various reasons.

Findings by the blood test and the ring test have been studied comparatively. Our impressions are these: cows strongly positive by blood test are almost invariably also positive by ring test; but those strongly positive by ring test are not always positive by blood test.

One example is a cow, calf-hood vaccinated, now in her third lactation, always negative to the blood test, and always giving a strong ring reaction in the milk from 3 quarters, the left front quarter always giving negative milk to the ring test. The strong ring test reactions and nega-

tive blood titers prompted us to have the milk from this animal checked bacteriologically and serologically. The following results were reported:

Blood titer—Negative.
 Ring test results—Strongly positive in all quarters except left front quarter which was negative.
 Bacteriological results of milk—Negative for *Brucella*.
 Serological results—Guinea pig blood titer (after injection of cream) was complete 1:50. The guinea pig blood serum was found negative for *Brucella* upon bacteriological analysis.

(The above bacteriological and serological results were reported by Dr. H. S. Bryan, Assistant Professor, Department of Animal Pathology, University of Illinois.

It is difficult to comprehend how the agglutinins or antibodies can be present in the milk without being present in the blood. One will have to conclude that the ring test reaction could be due to some non-specific agent and not due to *Brucella* infection.

We have found a number of cases where cows have been giving milk with positive ring tests for a period of one month to a year before showing a blood titer. These cases are the ones that should be bled every three or four weeks because a small

percentage of these cows will eventually show a blood titer warranting their disposal.

In a herd where blood testing is done regularly and ring tests made every two or three weeks, one would expect the incidence of blood reactors to be very low. The combination of blood testing and ring testing will cover all animals whether lactating or dry.

USEFULNESS OF RING TEST

The ring test can be viewed as an effective screening procedure. It will not replace the blood test; but it can minimize unproductive blood testing.

We have observed certain limitations of the ring test; they are:

1. It is less accurate than the blood test for individual animals.
2. It is only usable on lactating cows.
3. It does not work satisfactorily on colostrum milk.
4. It is not always reliable on abnormal milk or milk with poor creaming ability; however, some of this could be overcome by adding known negative milk with good creaming ability.
5. So far, we have found that the ring test does not help to determine whether a blood titer is the result of vaccination or an active infection.

(Continued on page 121)

VACCINES IN DAIRY ANIMAL DISEASE CONTROL*

S. F. SCHEIDY, V.M.D.

Medical-Research Division, Sharp & Dohme, Inc., Glenolden, Pa.

A number of important diseases of dairy cattle can be prevented by the use of vaccines. Such vaccines are produced and distributed under the supervision of the United States Bureau of Animal Industry.

In this article pertinent information is given with respect to vaccines for use against anthrax, blackleg, malignant edema, bacillary hemoglobinuria, brucellosis, hemorrhagic septicemia, and several other less important diseases of dairy cattle.

A NUMBER of important infectious diseases to which dairy cattle are susceptible can be prevented or controlled by vaccination. Some of these diseases are widespread in this and other countries, while others are more or less localized and sporadic. Vaccination of cattle for certain diseases is done routinely and in other instances only when disease outbreaks occur in a locality. All vaccines for use in animals are produced under the supervision of the Bureau of Animal Industry, United States Department of Agriculture. Each lot of vaccine must pass satisfactory tests for purity, safety, and toxicity prior to distribution.

The administration of vaccines to cattle is a surgical procedure and certain precautions with regard to technique must be followed. The selection of the animals to be vaccinated, their age and condition must be considered in order to obtain the most favorable results.

Anthrax (Splemic Fever, Charbon)

This is an acute septicemic disease caused by *Bacillus anthracis*. The herbivorous animals, especially cattle and sheep, are affected by it. Other animals also are susceptible to infection. Anthrax can be controlled by immunization of susceptible animals.

Anthrax spore vaccines are used widely in the vaccination of cattle against this disease. Spore vaccines usually are identified with a numeral ranging from #1 to #4. The dif-

ference in these vaccines is the degree of attenuation of the organisms with respect to virulence. No. 1 spore vaccine will kill mice, No. 2, mice and guinea pigs, No. 3, guinea pigs and occasionally rabbits, and No. 4, rabbits. The No. 4 vaccine generally is used for vaccination of cattle. Agents such as alum or saponin are added to spore vaccines to delay the absorption of the organisms.

The subcutaneous route usually is used for the administration of these vaccines; however, in recent years the intradermal method has met with favor in some areas.

Anthrax bacterin consisting of whole washed cultures of organisms killed by a chemical, usually formalin, also are used. The immunity produced by these bacterins may not be quite as marked as that produced by the spore vaccines.

Simultaneous Method

This method consists of the simultaneous administration of spore vaccine at one site of the body and anthrax antiserum in a different part of the body.

Blackleg (Black quarter; Emphysematous Gangrene; Symptomatic Anthrax)

This is an acute generalized infection generally found in cattle that is caused by *Clostridium chauvoei* (*Cl. fesceri*). Blackleg is a disease of young cattle, animals between the ages of 6 months and 2 or 3 years being most susceptible. Humans are not susceptible to this disease. Losses from blackleg readily may be prevented by vaccination, and very satisfactory vaccines are available.

Blackleg bacterin probably is the most popular agent used in the control of this disease. It consists of whole cultures of *Clostridium chauvoei* treated with formalin. Alum or aluminum hydroxide usually is added to delay absorption at the site of injection. Cultural aggressin, which is a bacteria-free filtrate of cultures of *Cl. chauvoei*, as well as natural aggressin prepared from

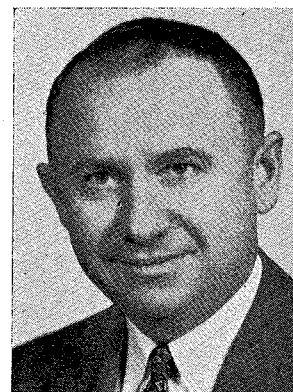

DR. SCHEIDY graduated from the School of Veterinary Medicine, University of Pennsylvania in 1929. For six years he worked with several milk companies as a field man on quality control and conducting physical examinations on dairy cattle. He spent one year as research associate at the University of Pennsylvania conducting investigational studies on bovine mastitis. For over six years he was instructor in medicine and resident veterinarian at the University of Pennsylvania. During the past eight years he has been serving as Veterinary Medical Director for the Medical-Research Division, Sharp & Dohme, Inc., Philadelphia, Pennsylvania. He is conducting experimental and clinical studies with new biological and pharmaceutical agents in the control of animal diseases.

tissues harvested from blackleg cases, also are effective antigens.

Blackleg and Malignant Edema

These two diseases are rather difficult to differentiate clinically and they may occur in animals concomitantly in the same locality. In such instances, a combination of vaccines is used. As previously stated, blackleg is caused by *Clostridium chauvoei* and malignant edema is caused by *Clostridium septicum*. *Clostridium chauvoei-septicum* bacterin containing 50 percent of each type of organisms chemically killed in whole culture is used prophylactically.

Bacillary Hemoglobinuria (Red Water Disease)

This is an infectious disease to which cattle are susceptible; it is caused by *Clostridium hemolyticum*. This disease is recognized in the western part of the United States. Vaccination of susceptible animals with whole cultures of *Clostridium hemolyticum* organisms chemically killed with formalin and alum precipitated apparently produces satisfactory protection. Yearly vaccina-

* Presented at the Thirty-seventh Annual Meeting of the INTERNATIONAL ASSOCIATION OF MILK AND FOOD SANITARIANS, INC., Atlantic City, New Jersey, October 13-16, 1950.

tion may be necessary in badly effected areas.

Brucella Abortus (Bangs Disease; Contagious or Infectious Abortion)

This disease is very important to the dairy industry. Probably it is the most serious infectious disease affecting dairy cattle.

The disease in itself does not cause as great a mortality in the adult animals as do some other pathologic conditions, but since it affects calf morbidity and mortality as well as the production and reproduction of adult cattle, it is indeed an expensive disease for the dairy industry.

Over the years various methods for the control of brucellosis have been employed, but it is only in recent years that an effective vaccine has been used widely.

Brucella abortus (Strain 19), an organism considered to be of low pathogenicity and high antigenicity, was isolated by Dr. J. M. Buck. Vaccines containing this organism are used extensively for the vaccination of cattle, especially calves, against brucellosis. Under certain circumstances, this vaccine also is used in the vaccination of mature animals.

The liquid vaccine consists of a suspension of live *Brucella abortus* (Strain 19) organisms in saline solution. At time of release for distribution each milliliter of vaccine must contain 10 billion viable organisms. A dose of 5 to 6 ml of the vaccine is given subcutaneously. There is some difficulty in maintaining the viability of the organisms in liquid medium for any appreciable length of time. It is essential that the liquid vaccine be kept refrigerated from time of preparation until time of use. Excessive agitation of the vaccine also has a detrimental effect on the living bacterial cells in liquid suspension; thus this too should be guarded against. At the present time the dating on the liquid vaccine from time of harvest to time of use is 90 days.

In view of the above mentioned problems in connection with the preparation and distribution of *Brucella abortus* vaccine the technique of desiccation by lyophilization has been employed in the preparation of the vaccine. The living organisms are suspended in skimmed milk, quickly frozen, and lyophilized. The

containers of vaccine are sealed under vacuum and in this manner viability of the organism may be maintained for long periods of time. This technique has made it possible to bring to the farm, where cattle are to be vaccinated, so-called "laboratory fresh" vaccine. When properly handled, this assures the owner and the operator that the animals to be vaccinated will receive a maximal number of living cells as vaccine. The dry vaccine is restored with sterile diluent at the time it is to be used. Restoration takes place within a few seconds after the diluent is added to the vaccine. The present dating on the desiccated vaccine is one year.

Experimental studies conducted with cattle in which the animals were challenged with virulent organisms of *Brucella abortus* indicated that good protection is obtained in a high percentage of the animals vaccinated with the vaccine. These experiments have been conducted with cattle vaccinated as calves and challenged during the 1st to the 5th pregnancies; the results were compared with those obtained using comparable animals not previously vaccinated.

The administration of *Brucella abortus* vaccine causes a positive serum agglutination when the serum is tested with *Brucella* antigen. This reaction is transient and of short duration in a high percentage of the animals when they are vaccinated at 4 to 8 months of age. A few of them persist in showing a positive reaction in such tests and it is not known definitely whether such reactions are due to the vaccine or whether the animals have acquired natural virulent infection.

The intradermal method of vaccination with *Brucella abortus* vaccine has been and still is being used by some individuals. In most comparative tests where this method was compared with the subcutaneous method, the results were essentially the same. One of the chief drawbacks to the intracutaneous method of vaccination is the difficulty of accurately administering a small dose of the vaccine intradermally and the subsequent local swelling. Usually the vaccine is placed in the caudal fold, which is the most convenient place for an intradermal inoculation in cattle. Local swelling and some induration may result from the procedure; this is undesirable since it

may make it difficult to interpret subsequent allergic tuberculosis reactions, because this site usually is used for such tests.

Mucoid Vaccine

A brief statement with respect to Mucoid *Brucella abortus* vaccine (Huddleson) may be of interest. The following report¹ was prepared by the Subcommittee on Research of the National Brucellosis Committee. The National Brucellosis Committee is composed of delegates and alternates from twenty-two nationwide farm, educational, professional, and research organizations. The Committee is devoted to a policy of controlling and eventually eradicating brucellosis from the nation's livestock industry, and thereby eliminating the reservoir of infection in man.

- "1. The exact make-up or content and the exact methods of production of M-vaccine have not been described. This is unique in the history of such products.
2. A permit for the production of M-vaccine for interstate sale has not been requested of the Bureau of Animal Industry by those concerned. Before a license of this nature can be granted, the firm or individual must submit satisfactory proof of proper production facilities, production procedures, proper labels and experimental protocols and literature showing the value of the product.
3. Adequate, controlled experiments have not been conducted; hence, neither the merits nor the dangers of M-vaccine are known.
4. When employed in cattle, M-vaccine has not produced appreciable blood reactions such as those encountered with Strain 19.
5. Whether or not M-vaccine is dangerous for people is not known.
6. Patience is advised while M-vaccine is being evaluated."

Hemorrhagic Septicemia (Pasteurellosis *bovis*; Shipping Fever; Stock-Yards Pneumonia)

This is an acute infectious disease to which cattle are susceptible. *Pasteurella* organisms are considered to be responsible for the infection; however, there is some con-

troverly regarding the etiology of this syndrome. The disease has been recognized for many years and frequently occurs in connection with the shipment of cattle from one part of the country to another. Herds, where additions frequently are made, also have outbreaks among the so-called native cattle.

Hemorrhagic Septicemia Bacterin consisting of whole cultures of chemically-killed *Pasteurella* organisms, especially *Pasteurella bubal-septicus* (*Pasteurella multocida* Type 2), appear to be of value in raising the resistance to such infections. For best results it is important that the vaccine be administered several weeks or a month prior to transportation of the cattle or to those that may be exposed to the disease. Several doses, administered a week or two apart, are desirable.

Hemorrhagic Septicemia Aggressin is produced by injecting subcutaneously cultures of virulent organisms into animals, usually horses or cattle. The injection usually is made into the neck and a severe edematous swelling develops in the neck and brisket regions within 24 hours. The animals are sacrificed and affected tissues are harvested. From such tissue, fluids are expressed and filtered, and a preservative is added. This material, in relatively small doses, is used to vaccinate animals. Aggressin used on cattle should be of bovine origin in order to minimize the chance of anaphylaxis.

Corynebacterium-Pasteurella Bacterin

In many cases of so-called hemorrhagic septicemia or shipping fever, a variety of organisms are found in large numbers. Both *Pasteurella* and *Corynebacterium pseudodiphthericum* (bovis) are present, and by some are considered to be important from an etiological standpoint. For this reason cultures of both of these organisms, 50 percent of each type, are included in the bacterin. The bacterin consists of the whole culture of chemically-killed organisms to which alum is added. This bacterin is used widely and some individuals believe it to be a more effective vaccine for the prevention of the clinical syndrome known as hemorrhagic septicemia (shipping fever) than is the straight *Pasteurella* bacterin.

Rabies

The disease is not tremendously important as compared with some of the other diseases of dairy cattle in this country. In areas, however, where rabies in dogs and wild animals, especially foxes, is a serious problem, the incidence of it in cattle may be of economic importance. Usually it is considered that once an animal is definitely infected with rabies virus, it will succumb to the disease. Bite wounds in cattle produced by rabid animals frequently are in the head region. This is particularly serious, since the location of the infected wound with respect to the brain apparently influences the rate of development of rabies in the exposed animal.

Veterinary rabies vaccine is produced in horses or goats. Other animals such as sheep and cattle too can be used, but are more expensive. Fixed rabies virus, given intracerebrally, is used to infect them and after the proper incubation period the brain of the animal is harvested. The brain tissue is finely ground and the substance is treated with phenol to inactivate the virus. Potency tests are conducted on each lot of vaccine to determine that it is antigenic. This type of vaccine is used in cattle that have been exposed to rabid animals or prophylactically in areas where an epizootic of rabies exists.

Mixed Infections

There are several disease conditions apparently caused by bacteria that develop in cattle, but the etiologies of these are not clear. It is considered that these conditions are due to a so-called mixed bacterial infection. A variety of organisms are present in tissues of affected animals. As an aid in the prevention of these conditions, the so-called mixed bacterins are administered. They consist of various combinations of the organisms commonly found in animals with these conditions. Whole broth cultures of chemically-killed organisms are used in the preparation of these vaccines.

Warts

Certain dermatologic manifestations in the form of wart-like growths are observed in cattle. One type of these warts (seed warts) is

caused by a virus; the lesions usually are found in the neck and shoulder regions of cattle. (This wart is not related to the squamous type found on the teats of cows.)

Vaccine prepared by propagating wart virus in chick embryos apparently is effective. Several subcutaneous inoculations, or one subcutaneous and one intradermal one, usually are given. This is a relatively new type of vaccine, but currently it is thought to be useful for the prevention of seed warts in cattle.

Foot and Mouth Disease

The disease is not present in this country at this time and perhaps reference to it is irrelevant. However, both the cattle industry and the veterinary profession have been greatly concerned about the problem since the fall of 1946 because of the proximity of the disease to our southern border.

This country has aided greatly in the control of the infection in susceptible animals in Mexico and also in research work resulting in new methods for the production and use of vaccines for foot and mouth disease.

Several types of virus, known as types A, O, and C, are capable of causing foot and mouth disease in susceptible animals. A vaccine prepared from scrapings from the tongues of artificially infected animals has been very useful in the control of foot and mouth disease in Mexico and in some European countries. Repeated vaccinations at 4 and/or 6 monthly intervals for several years may be necessary to establish resistance in animals in a given area.

Extensive research work designed to develop methods of control of foot and mouth disease is being conducted at the present time in Mexico and in some European countries. American veterinarians are participating in this work so that they can become familiar with the problem and with new developments, and thus be in a better position to cope with the disease should we be confronted with it in this country.

REFERENCE

1. Knox, W. D. Present Status of Brucella "M"-Vaccine. *Veterinary News*, 13, No. 3, May-June, 1950.

RESEARCH AS IT AFFECTS THE MILK SANITARIAN*

E. L. JACK

Chairman, Division of Dairy Industry, University of California, Davis

The milk sanitarian occupies a special place in the dairy industry with equal responsibility to all segments: producers, processors, distributors, and consumers. The entire industry is dependent upon the technical competence and personal integrity of the members of this group. The primary function of the milk sanitarian is the enforcement of regulatory laws. The regulatory laws are by their nature restrictive in character and by reason of this restrictive nature tend to limit the application of research. The milk sanitarian of the future will need to have knowledge that will enable him to exercise judgment in a much wider field than is now necessary. As research findings continue to modify processing techniques, it is their responsibility, first, to insure the safety of the public from harmful materials, and secondly, to avoid unnecessary restrictions that will retard desirable progress.

It is with a warm feeling of pleasure that I address this organization, the California Association of Dairy and Milk Sanitarians, because I number among your members many good friends of long years standing. I feel also a keen sense of responsibility and obligation to contribute in a worthwhile manner to your annual meeting program. That sense of responsibility and obligation stems in part from the high esteem with which I regard your individual and collective activities.

As a group, you occupy a special place in the dairy industry; you are *in* the industry but not *of* it. Your position is that of an intermediary with obligations to no single element of our industry, but with equal responsibilities to all segments: producers, processors, distributors, and consumers. To carry out these responsibilities in an effective and unbiased manner requires not only technical competence, but also personal integrity and tact on the part of the individual members of your group. The dependence which the entire industry places on your work, and the confidence with which your actions are accepted, testify fully that you and your colleagues

throughout the country possess these attributes. Your actions are consistently motivated by high purpose, and it is a privilege to talk to you on this subject in which I am so vitally interested.

I have chosen to talk about research and its effects on your activities. Since I seem to talk about it at every opportunity, I suspect that eventually people may get the idea that I believe research is important. And if they do get that idea, they will be right. Research is of the utmost importance to the dairy industry. I should like to point out just how various phases of the dairy industry are affected by it, because you in the regulatory service are affected directly or indirectly by everything that affects any part of the industry.

RESEARCH DEFINED AND ILLUSTRATED

First, what is research? Research is the discovering of new facts and principles. It is sometimes extended also to the application of these principles or the putting them to work. But the *discovery* is the first order of business. Once facts are known, they will be put to use in due time. Sometimes new facts are of immediate usefulness, and sometimes their value does not become apparent for a long time. But *no one* can estimate the value of a *new fact*.

To take a familiar example: Louis Pasteur accomplished many things in his life, but all the rest of them pale into insignificance beside the discovery of the fact that heat would destroy organisms of fermentation in wine. Who can say what that new fact has been worth to the food industry? Or to cite another example, someone observed many years ago that changing the intensity of light, impinged on some metal surfaces, generated an electric potential. Not a very exciting observation in itself, but consider some of the uses this new fact has been put to. It will open doors for you without your lifting a finger. It will tell you how long to open your

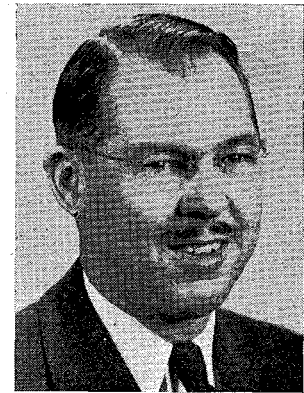

Dr. E. L. Jack, a native of Pennsylvania, graduated from Penn State College where he took his Ph.D. degree. After a year as research chemist with the Borden Co. he served as Assistant Professor and since 1946 as Chairman of the Division of Dairy Industry, University of California. His interests have been in dairy farming and management, and in the breeding of purebred Holstein Friesian cattle. He is a member of four honor societies, seven scientific societies, and three general clubs, and the author of over forty original papers.

camera lens to get a good picture. It will count automobiles on the highway, and lately it has been put to use sorting lemons into different size groups. Every day new uses are found for this simple fact. And so it is the discovery of new facts that makes technological progress possible.

RESEARCH IN DAIRY INDUSTRY

And now I would like to have you, consider with me the importance of research in specific fields in the dairy industry. First, let's take education, because you are all products of technological education, and because I am somewhat familiar with it. How do teaching and research supplement each other? In our land-grant colleges of agriculture, we have both experiment station research and classroom teaching.

Because the experiment station research is usually aimed at trying to solve some of the more pressing practical problems of the times, it is frequently thought of as being completely divorced from the teaching functions. This is far from the case. The research program provides the foundation for all teaching; it pro-

* Address delivered before the California Dairy and Milk Sanitarians, Alexandria Hotel, Los Angeles, California, October 25, 1950.

vides the subject matter. Without research we should be using the same textbooks that were in use 50-75 years ago. Textbooks need frequent revision these days because of the pressure of new developments.

Research also influences or should influence, the individual instructor. If he is to be aware of the latest developments in his field, he must, of necessity, be active in the research phases of his specialty. If he relies solely on textbooks for his subject matter, his teaching is stereotyped and lifeless, because textbooks are out-dated before they are printed. I maintain with sincere conviction that instruction at the University level is inadequate unless both the individual instructor and his departmental associates are simultaneously engaged in an aggressive research program. Their science then becomes a living, personal, and timely matter; it is not a mere repeating of second-hand textbook information.

It seems hardly necessary to discuss the effects of research on plant operational procedures because you are in contact with new developments continually. There are, however, some points in this connection I want to call to your attention. A few weeks ago our staff was requested to prepare a list of the technological developments in the dairy industry covering the period since 1930—the last twenty years. When we had the list compiled, together with a concise description of the individual items, it covered ten typewritten pages and included practically all of our present day processes. In other words our current operational procedures are developments of the last twenty years. This certainly is an impressive example of the impact of research on the dairy industry. These developments include our present cleaning practices, plate heat exchanges, paper containers, bulk handling on the ranch, direct steam injection heating and vacuum flash cooling as in "Vacreation." They include also metal churns, and continuous buttermaking, aseptic packaging, the widespread adoption of stainless steel as a fabricating metal, and the tremendous increase in homogenized milk. Others that might be mentioned include the phosphatase test which is a valuable tool for you, the adoption of continuous freezers for ice cream manufacture, and the packaging

developments for cheese, dry milk, and many other dairy products.

RESEARCH GENERATES CHANGE

This recitation of these developments should impress one fact strongly on your minds—and that is that *research generates change*; it is the enemy of stagnation; it promotes technological progress.

What then are the broad implications of the effects of research, this great catalyzer of change, on the work of the milk sanitarians? Your primary function is the enforcement of certain regulatory laws affecting the dairy industry. Now regulatory laws are by their nature restrictive in character. They set forth that certain essential acts shall be performed in a particular way; within their scope they retard changes; they tend to maintain the *status quo*. Therefore, you, as law enforcement officers, are the custodians of the *status quo*.

Such an analysis would seem to indicate that a milk sanitarian's duties place him in opposition to new developments. This may or may not be true. Certainly there are instances where it has worked that way. But you and I know, however, that *the group here today* has been a strong supporter of sound new developments, and I have every confidence that it will continue in that attitude. Certainly the milk sanitarians and the public health officers are entitled to the major share of the credit for the high sanitary quality of the milk in this country today. The problem of how to get a uniformly safe bottle of milk has been licked largely due to their ideals and efforts. The major developments in milk sanitation have been achieved. In this respect the continuing status is eternal vigilance to retain our present position.

The developments of the future will follow a different path and will require a wider and somewhat different scope of knowledge on the part of the regulatory officer, if he is to make a comparable contribution to progress in the future as he has in the past.

Research in dairy industry and its application in new developments will take the direction of emphasis on the individual milk constituents and their use in products which best serve the nutritional needs and taste desires of the consuming public. Indeed,

research of this nature is already in progress, and product applications are being made from it. This type of research and the applications from it will increase as time goes on.

We can expect to see on the market, in addition to our conventional products of today, what have aptly been called tailor made products; products made up of varying proportions of milk constituents processed so as to have predetermined properties. Because milk in its natural form is the ideal food for a young calf, it does not follow that its constituents are in the proper proportion for all uses by man. And so there is under way today a considerable amount of research that will tend to produce dairy products perhaps radically different from those we are so accustomed to today.

SOME POSSIBLE DEVELOPMENTS

It is conceivable also that competition may force us to abandon the long held notion that the composition of dairy products is "sacred" and nothing can be added to them. I believe the time will soon be at hand when we shall petition our regulatory agencies forcefully for permission to add specific harmless ingredients to many of our established dairy products in order to improve their flavor or prevent their rapid deterioration. We already know how to prevent some of the most troublesome flavor problems in the dairy industry through the addition of certain materials that are not only harmless but in many cases actually nutritious. I am sure that liberalization of our attitude will soon prevail.

Such developments as I have just mentioned will require careful conduct on the part of the present-day milk sanitarian. He will no longer be solely a milk sanitarian, in fact his scope is much wider than that now, and the term is a misnomer. The sanitarian, or his counterpart, will need to exercise careful appraisal and judgment first to insure the safety of the public from harmful materials, and secondly, to avoid unnecessary restrictions in retarding desirable progress.

I have not the slightest doubt that the milk sanitarians will continue to show the same leadership in this wider field that stamped their work when it was more nearly strictly sanitarian in nature.

New Books and Other Publications

Methods in Food Analysis—Applied to Plant Products, by M. A. Joslyn. Published by the Academic Press, Inc., New York. 1950. 525 pages. \$8.50.

Lecture notes used in courses in food analysis for twenty years constitutes the basis for this book. The author emphasizes the principles involved and arranges them according to the important method of analysis rather than to the examination of a particular food product. "The techniques described are illustrative of those used in the field, and these are discussed in more detail when the available information is scattered in

the literature. . . . This book is intended as a text and reference work on the physical and chemical methods used in the laboratory examination and evaluation of commercial fruit and vegetable products." An extraordinarily rich bibliography, 35 tables of illustrative data, and 42 well-drawn apparatus assemblies, and full mathematical discussion of analytical results makes the book unique as a supplement to a good course in food analysis as well as useful to the practical analyst (who too often follows blindly the instructions without realizing "what it is all about").

Organic Reagents for Organic Analysis, by The Staff of Hopkin and Williams Research Laboratory. Second Edition. Published by the Chemical Publishing Co., Brooklyn, N. Y. 263 pages. 1950. \$5.00.

This edition is an enlargement of the first edition, and includes some new reagents that have been developed since the first edition was published. The section on alkaloids that ran in the first edition has been deleted herein because of the un dependable data available. The material is conveniently arranged and carries good lists of bibliographic references.

THE DEVELOPMENT OF THE MILK AND FOOD SANITATION PROGRAM OF THE PUBLIC HEALTH SERVICE*

Early Studies

THE annual report of the U. S. Marine Hospital Service for 1896 included a report on cooperative work by the Hygienic Laboratory in connection with an investigation of the prevalence of typhoid fever in the District of Columbia. This report contained the following statement: "It is not improbable that if a comprehensive study be made of the water supply of the dairies supplying milk to Washington our knowledge of the relation which the milk supply bears to the prevalence of intestinal and other diseases would be proportionately increased."

Although the Public Health Service continued its interest in various phases of the public health aspects of the use of milk, it was not until 1907 that an extensive study was made of the problem. An investigation by the Service during the summer of 1906 of the origin and prevalence of typhoid fever in the District of Columbia revealed that milk was the agent of transmission in 10 percent of the 866 cases studied. Following this disclosure a thorough study, both practical and scientific in character, was made of the relation of milk to the public health. Results of this study were published as a Hygienic Laboratory Bulletin in 1908, and an enlarged and revised edition was published in 1909. Coincident with this

work, a study was made of thermal death points of pathogens in milk by Dr. Milton J. Rosenau. Results of this study gave impetus to the use of low temperatures for pasteurization of milk supplies, and were an important factor in development of the holding method of pasteurization as contrasted with the flash method in use at that time.

The Public Health Service took an active interest in various efforts directed toward improvement of milk supplies, among which was the certified milk movement. However, experience indicated that even the elaborate sanitary precautions recommended in this connection were not sufficient to ensure against the possibility of milk-borne outbreaks of disease. It became evident that in the extension of pasteurization of milk supplies lay opportunity for accomplishing the best results, and the Service devoted its energies in that direction. Pasteurization, however, was not perfect and, as commercial pasteurization of milk supplies increased, doubt developed not only as to the efficiency of some commercial pasteurizing machines but also as to the time and temperature standards used for commercial pasteurization.

In 1911, the New York Milk Committee appointed a group of experts designated as the Commission on Milk Standards to study and report upon rules and regulations for control of milk. The Public Health Service was represented on this commission at the time of its first and second reports, and published three reports of the commission in the Public Health Reports during the years 1911,



ABRAHAM W. FUCHS was graduated from Cornell University in 1913 with a C.E. degree in sanitary engineering and has been with the U. S. Public Health Service since 1916. He became chief of the Milk and Food Branch with rank of sanitary engineer director in 1940. He has edited the PHS Milk Code, the PHS Restaurant Code and PHS Annual Reports of Disease Outbreaks from Water, Milk and Food for many years, as well as authoring numerous publications on milk and food sanitation. He is a member of NRC Committee on Milk Quality, NSF Committee on Technical Research, and Syracuse University Advisory Board on Paper Sanitation and served as President of IAMFS in 1949.

1913, and 1917. In 1921, a large dairy corporation engaged a commercial public health laboratory to make an exhaustive study of time and temperature standards for commercial pasteurization of milk and of commercial pasteurization equipment in general use at the time. This research included engineering tests and bacteriological tests with pathogenic organisms generally recognized as transmissible by milk supplies. The Public Health Service cooperated in this research and published the results of the investigation in 1925 as Public Health Bulletin No. 147.

* (Written by Abraham W. Fuchs, Chief, Milk and Food Branch, USPHS, for inclusion in Dr. R. C. Williams' History of the Public Health Service; prepared in mimeographed form by the Planning and Development Branch, Division of Engineering Resources).

Office of Milk Investigations Established

Milk sanitation investigations became a definite activity of the Public Health Service in 1923. At that time, the Alabama State Board of Health, feeling the need for a State-wide milk control program, requested the assistance of the Service in the development of such a program. Sanitary Engineer Leslie C. Frank was assigned to cooperate with the Alabama State Board of Health in this work. This action inaugurated the activities of the Office of Milk Investigations of the Division of Scientific Research.

This Office later went through a number of administrative changes. It was made a part of the Division of Public Health Methods in 1937, became the Milk and Food Unit of the Sanitation Section of the Domestic Quarantine Division in 1939, the Milk and Food Section of the Sanitary Engineering Division in 1944, and finally the Milk and Food Branch of the Division of Sanitation in 1948. When Frank was made chief of the Sanitation Section in 1939, Sanitary Engineer Abraham W. Fuchs succeeded him in charge of the milk and food program.

Origin of Standard Milk Ordinance

The work in Alabama centered around a cooperative effort to unify milk control methods throughout the State by the development and enforcement of an effective type of milk legislation. This cooperative program was put into effect in Alabama by the State Board of Health, with the Public Health Service representative acting in an advisory capacity.

In the preparation of this milk legislation, a thorough study was made of a large number of milk ordinances in effect at that time. One striking fact brought out in this study was that practically no two milk ordinances contained the same requirements. This multiplicity of requirements indicated the need for a milk ordinance which would be applicable to communities in general, and led to development in 1924 of the milk ordinance which was first known as the Standard Milk Ordinance and later as the Milk Ordinance Recommended by the U. S. Public Health Service.

This ordinance was of the grading type, with provision for degrading as a temporary punitive measure. More recent editions of the ordinance, however, contain alternative provisions with reference to grades of milk products which may be sold. This was done because some communities prefer to use the grading and degrading system of improving milk quality, whereas others prefer to use exclusively the system of forbidding sale of milk and milk products which do not comply with all items of sanitation, and instituting court procedure if the violator persists in selling.

The success of the milk sanitation work in Alabama attracted the attention of other States and cities, and within three years nearly 100 communities had enacted this milk ordinance into law. At the request of the State health department, a milk specialist was assigned to such States as Texas, Mississippi, Missouri, Kentucky, North Carolina, Arkansas,

Tennessee, and Arizona during the first decade of the program to assist them in organizing a milk sanitation program and to study the effect of applying a uniform State-wide program. Surveys were made in Alabama by Frank (1927), in Mississippi by Fuchs (1930), and in Missouri by Dr. Franklin A. Clark (1931), in which the milk sanitation status of a number of communities was determined both before and after the adoption of the Standard Milk Ordinance so as to measure the results of the enforcement of the ordinance. In May 1926, the Standard Milk Ordinance of the U. S. Public Health Service, slightly modified, was adopted as a standard for the United States by the Conference of State and Territorial Health Officers. As the number of adoptions increased, it was apparent that consideration needed to be given to a national program for the unification of milk control. A program of this nature was developed by the Service. It consisted of the voluntary adoption and strict enforcement of the milk ordinance by States and communities, the organization of State milk sanitation programs, the milk sanitation rating of communities by the State authorities, and the training of State milk sanitarians, with technical advice and occasional check milk sanitation ratings by the Public Health Service.

Standard Milk Code

With the growth in the number of adoptions of the ordinance, it soon became evident that even though a number of communities adopted the same milk ordinance, the interpretation and enforcement of the ordinance were not necessarily uniform. This fact led to the formulation of the Standard Milk Code, later known as the U. S. Public Health Service Milk Code, which discusses the Standard Milk Ordinance item by item, outlines in each case the public health reason therefor, and gives what is recommended as satisfactory compliance with each item. The first edition of the Code, a tentative draft, was published in mimeographed form in 1927.

During its formulation, the Standard Milk Ordinance and Code was referred to a number of public health and dairy organizations for critical study in order to have the advantage of review by a large number of groups and individuals. After a series of conferences with the Bureau of Dairy Industry of the U. S. Department of Agriculture, the 1931 and succeeding editions of the Milk Ordinance and Code have carried the approval of that organization.

In 1932, the Public Health Service appointed a Board of Consultants, termed the Public Health Service Milk Sanitation Advisory Board, so that it might have at its command the technical advice

of a comprehensive group of experts in the various phases of the public health control of milk supplies, and in allied problems relating to the production, processing, and distribution of milk. The various suggested modifications of the Milk Ordinance and Code received from time to time are presented to the Advisory Board for discussion and recommendation. The 16-member Milk Sanitation Advisory Board was replaced by a seven-member Sanitation Advisory Board to advise on all sanitation activities when the Sanitary Engineering Division was established in 1943. In 1947, a separate Milk and Food Sanitation Advisory Board was appointed as consultants on milk and food. In 1949, two industry members were added, one nominated by the Dairy Industry Committee, the other by the National Restaurant Association.

New editions of the Public Health Service Milk Ordinance and Code are published at such times as revisions in the ordinance or code make advisable the publication of a new edition. Eleven editions of the Milk Ordinance and Code have been issued, the first printed edition having been published in 1935 as Public Health Bulletin No. 220, and the latest revision in 1939. A revised milk ordinance alone was prepared in 1949, but printing of the accompanying code is not expected before 1951. All editions beginning with that of 1933 were compiled by Fuchs.

Extent of Adoption of Milk Ordinance

The first State to adopt the model milk ordinance as State regulations was Kentucky, in 1925. Then came Mississippi in 1927, Alabama in 1929, and North Carolina in 1930. The first large cities to adopt the ordinance were Mobile and Montgomery in 1923, Knoxville in 1924, and Atlanta and Chattanooga in 1925. The first counties adopted it in 1927. At the present time* the ordinance is in effect in 1,468 municipalities and 367 counties and districts located in 38 States and one Territory. It has also been adopted as State law or regulations in 32 States and two Territories, in 13 of which it is enforced State-wide. Included are 55 cities of over 100,000, and 38 cities between 50,000 and 100,000 population. It is in effect in areas with a total population of over 58,000,000.

Included in the list of adoptions are four States, ten counties, and 392 municipalities with compulsory pasteurization of all market milk or all except certified. In addition the list includes 36 counties and 269 municipalities with 100 percent pasteurization on a voluntary basis.

Following is a chronological cumulative summary of adoptions at 5-year intervals:

* March 1951.

Year	State Law or Regulations	Enforced State-wide	Counties or Districts		Population Covered
			Municipalities		
1925	1	0	0	64	1,700,899
1930	2	0	81	371	8,813,803
1935	3	0	96	573	16,483,354
1940	12	2	161	872	22,695,285
1945	25	7	238	1131	35,452,348
1950	34	13	367	1468	58,878,145

Investigations Necessary in Development of Code

Investigations on the efficiency of commercial milk pasteurization equipment were undertaken in 1926 by Sanitary Engineers Frank and Frederic J. Moss, and Milk Specialist Peter E. Lefevre. This work included studies of the design and operation of milk pasteurization equipment and of temperature indicating and recording devices. Wherever possible, the tests were carried out in commercial milk pasteurizing plants during actual routine operation. In the temperature studies of pasteurizers, the temperatures of the milk at various points in the apparatus were determined by means of thermocouple-potentiometer equipment. The studies indicated that some of the equipment then in use could not be depended upon to pasteurize effectively. Some of the defects found consisted of "dead ends" or "cold pockets" which were beyond the influence of heating and agitation devices, foam which was lower in temperature than the milk, leakage of milk past inlet and outlet valves, lack of dependability of some temperature control equipment, and other problems.

As a result of these findings, many of the pasteurization equipment manufacturers modified designs of their equipment, and later studies indicated the practicability of eliminating the defects mentioned. The testing work also disclosed that the deviations between the hottest and coldest milk could be kept within one degree F. in properly designed pasteurizers.

For a considerable period of time following the replacement of flash pasteurization by the holding method in this country, use of flash pasteurization was not considered acceptable by American health officials due to its lack of dependability. The old flash heaters were used only for preliminary heating prior to holding. However, due to improvements in design of heaters, and in temperature control and safety devices, there developed a demand for recognition of flash pasteurization as an acceptable method. Beginning in 1927, the U. S. Public Health Service, in cooperation with the New York State and New York City Health Departments, made studies of electric flash pasteurization, including engineering observations and tests with pathogenic bacteria. Later the Public Health Service made similar studies of an internal tubular type of steam flash pasteurizer, and in cooperation with the Pennsylvania State Health Department made engineering tests of a plate-type steam flash pasteurizer. On the basis of this work, it was recommended that local and State health authorities approve provisionally the use of equipment which would heat every particle of milk to not less than 160 degrees F., followed by a holding period of not less than 15 seconds at not less than this temperature. It was specified that the equipment must comply with certain listed specifications, including a safety device designated as an automatic milk-pump cut-out which

would stop the milk pump when the milk temperature at the heater outlet dropped below the legal requirement. Because of the use of a short but definite holding period in this method, it was designated as high-temperature, short-time pasteurization rather than flash pasteurization. Since 1933, the definition of pasteurization in the Public Health Service Milk Ordinance and Code has included the temperature and time combination of 160 (changed to 161 in 1949) degrees F. for 15 seconds in addition to that of 143 degrees F. for 30 minutes.

Because of the increase in use of hot-air cabinets for the bactericidal treatment of milk cans, tests were made in 1937 by Sanitary Engineers Frank, Moss, and Fuchs; Veterinarian William H. Haskell; Milk Specialist Milton M. Miller; and Bacteriologists Robert C. Thomas and Mildred K. Havens, to determine an effective and practicable temperature and holding time that would ensure the desired reduction of milk-borne pathogens. This study was made using as a test organism a strain of *Escherichia coli* which was more heat-resistant than the most resistant pathogen transmissible through milk supplies. Results of this work indicated that if hot-air cabinets are operated so that the coldest portion is at not less than 180 degrees F. for at least 20 minutes, milk cans contained therein will be subjected to adequate bactericidal treatment.

The use of regenerators (also known as heat exchangers or regenerative heater coolers) presents a possible source of contamination of the pasteurized milk by the raw milk. This might occur either directly, as in milk-to-milk regenerators, or indirectly, as in milk-to-water-to-milk regenerators, unless certain requirements are met as to relative pressures in the system. The technical difficulties involved in complying with adequate requirements were such as to warrant a detailed study of the problem by Fuchs in 1938. The article dealing with this study outlines the problem and describes methods for automatically ensuring the required relative pressures in various types of milk-to-milk and milk-to-water-to-milk regenerators.

Practically all valves used in milk lines will leak sooner or later, due to the inevitable scoring of the seat during service, and tests indicated that leakage in some cases amounted to as much as 2.7 percent of the pasteurizer contents. In the study made of valve leakage the principle followed was not the development of a leak-tight valve, but instead the design of valves, both inlet and outlet, which would protect against leakage of incompletely pasteurized milk into the pasteurized supply. Several designs of leak protector valves were developed by Fuchs in 1938 and were made available to the industry by publication in Public Health Bulletin No. 220.*

* A list of publications pertaining to milk and food sanitation may be obtained from the Milk and Food Branch, Division of Sanitation, Public Health Service, Washington 25, D. C.

In practically all cases where foam is present, it is lower in temperature than the milk, and foam temperatures were encountered which were as much as 35 degrees F. lower than the temperature of the milk during the holding period. Heating of the air space above the milk using enclosed steam or electric heaters was not satisfactory because of the tendency of the dry hot air to rise away from the foam and thus not heat it. However, it was found that live steam admitted to the air space above the milk not only heated the foam but also tended to dissipate it. Designs of air-space heaters were developed in 1939 by Moss and Fuchs for various types of pasteurizers.

Although automatic pasteurization installations, either of the 30-minute or the high-temperature short-time type, must of necessity be provided with thermostatic control of the temperature of the milk, the Public Health Service Milk Ordinance and Code also specifies that such installations be provided with automatic milk-flow stops. Automatic milk-flow stops are devices which stop the forward flow of milk whenever its temperature drops below the required limit due to any cause whatsoever, and automatically restore forward flow when it again reaches the required temperature. The requirement for the use of milk-flow stops necessitated the development of specifications for the design of the flow stops and for their location.

There has been a decided trend toward the use of automatic pasteurization equipment, especially in the larger plants. With this greater use of automatic equipment, there has been an accompanying increase in the sanitary engineering problems involved. In addition to the milk-flow stops previously mentioned, there are other safeguards both of design and operation, which are necessary for automatic systems, to ensure that the required pasteurization temperature and time will be applied to every particle of milk and milk products. These safeguards naturally fall into two main classifications, namely, those dealing with temperature control and those dealing with time control.

In recent years milk has been implicated in the transmission of the Q fever rickettsia, *Coxiella burnetii*. Studies by the National Institute of Health and the California State Department of Health in 1948 indicated that *C. burnetii* occasionally survives pasteurization by both the vat process and the high-temperature short-time method. Accordingly, a study was begun early in 1950 at Davis, California, financed jointly by the University of California and the U. S. Public Health Service, to determine the thermal death times of *C. burnetii* in milk at various temperatures. The laboratory scale studies now in progress will be followed by full scale experiments in commercial pasteurization equipment of various types. The results will determine whether the present pasteurization temperature-time standards are adequate.

(To be continued in next issue)

Association News

Affiliates of

INTERNATIONAL ASSOCIATION OF MILK AND FOOD SANITARIANS

ASSOCIATED ILLINOIS MILK SANITARIANS
President, D. B. Morton.....Springfield
Vice-President, James A. Meany.....Chicago
Secretary-Treasurer, P. E. Riley, Illinois Dept. of Public Health, Chicago
Sergeant-at-Arms, Dr. L. E. Booth.....Gardner
Executive Board Members:
 C. G. Gibson.....Chicago
 Dr. W. H. Haskell.....Beloit, Wis.
Auditors:
 F. V. Lee.....Elgin
 H. B. Richie.....Chicago

DUBUQUE DAIRY TECHNOLOGY SOCIETY
President, John Stanton.....Dubuque
Vice-President, Fred Ament.....Dubuque
Secretary-Treasurer, Ralph Howard.....Dubuque

FLORIDA ASSOCIATION OF MILK SANITARIANS
President, P. D. Shirley.....Tampa
Vice-President, L. T. Smith.....Jacksonville
Secretary-Treasurer, H. H. Wilkowske.....Gainesville
Members of Executive Committee:
 R. R. Hood.....Pensacola
 L. L. Chaffee.....St. Petersburg
 L. A. Scribner.....Orlando

IOWA ASSOCIATION OF MILK SANITARIANS
President, A. T. Getz.....Ames
Vice-President, F. W. Kreamer.....Manchester
Secretary-Treasurer, R. A. Belknap, City Department of Health, Des Moines

KANSAS ASSOCIATION OF MILK SANITARIANS
President, Roy Mitchell.....Arkansas City
First Vice-President, Ray Fair.....Parsons
Second Vice-President, Grove Gilliland.....Dodge City
Secretary-Treasurer, Ivan Van Nortwick, Chief Milk Sanitarian, State Board of Health, Topeka
Auditors:
 Don Reed.....Coffeyville
 Wilbur Palmer.....Wichita
Public Relations, Gene K. Lockard.....Topeka

MICHIGAN ASSOCIATION OF SANITARIANS
President, M. Wilson.....Ludington
First Vice-President, L. Littlefield.....Lansing
Second Vice-President, W. L. Ettesvold.....Grand Rapids
Secretary-Treasurer, James Axelson, Health Department, Ann Arbor
Assistant Secretary-Treasurer, M. Hilbert.....Eloise
Board of Directors:
 J. Peters.....Sault Ste. Marie
 C. V. Roose.....Hillsdale
 W. L. Mallman.....East Lansing

MINNESOTA MILK SANITARIANS ASSOCIATION
President, Owen Owens.....Rochester
Vice-President, Thomas Stibal.....Hutchinson
Secretary-Treasurer, Dr. J. C. Olson, Jr., Associate Professor of Dairy Bacteriology, Dairy Division, University of Minnesota, St. Paul 1, Minn.
Board of Directors: Ruben W. Koivisto, Leonard G. Sinton, Robert R. Dalton, C. H. Mattson, Reuben M. Olander, A. L. Sjwall.

MISSOURI ASSOCIATION OF MILK AND FOOD SANITARIANS
President, G. F. Reeves, Director of Food Control, St. Louis, Mo.
Vice-President, J. H. Barlow, Pulaski County Health Dept., Waynesville, Mo.
Secretary-Treasurer, J. L. Rowland, Director, Bureau of Food and Drugs, Jefferson City, Mo.

NEW YORK STATE ASSOCIATION OF MILK SANITARIANS
President, A. B. Quencer.....New York City
Vice-President, Claude Woodward.....Utica
Secretary-Treasurer, C. W. Weber, 18 Dove St., Albany 6, N. Y.

OKLAHOMA ASSOCIATION OF MILK AND FOOD SANITARIANS
President, Harper Orth.....Shawnee
First Vice-President, Clyde Harris.....Oklahoma City
Second Vice-President, D. C. Cleveland.....Durant
Third Vice-President, R. Kay Matthews.....Wewoka
Secretary-Treasurer, R. L. Howell.....Tahlequah

VIRGINIA ASSOCIATION OF MILK SANITARIANS
President, J. D. Hanbury.....Portsmouth
Vice-President, C. G. Knick.....Lexington
Secretary-Treasurer, A. A. Pais, State Health Department, Richmond
Auditors:
 L. A. Huff.....Roanoke
 D. L. S. Woods.....Waynesboro

WISCONSIN MILK SANITARIANS' ASSOCIATION
President, Palmer Welsh.....New Glarus
Vice-President, Myron L. Clark.....Oshkosh
Secretary-Treasurer, L. W. Brown, Wisconsin State Department of Agriculture, Madison
Directors:
 George E. Carroll.....West Allis
 Leo W. Neitzel.....Wisconsin Rapids
Auditors:
 C. A. Mohr.....Madison
 Vivian G. Rowley.....Madison

Associations Which Have Designated the JOURNAL of MILK and FOOD TECHNOLOGY As Their Official Organ

CALIFORNIA ASSOCIATION OF DAIRY AND MILK SANITARIANS
President, B. Q. Engle, San Francisco 21, California
First Vice-President, Robert L. Clayton, San Diego, California
Second Vice-President, E. H. Biles, Sr., Oakland 9, California
Secretary-Treasurer, D. A. Cordray, California State Department of Agriculture, Bureau of Dairy Service, 1035 Jennings Avenue, Santa Rosa, California
Auditors, Earl Eichner, State Department of Agriculture, San Francisco, California
 J. R. Foster, Los Angeles, California

CENTRAL ILLINOIS DAIRY TECHNOLOGY SOCIETY
President, L. P. Harder.....Decatur
Vice-President, M. B. Burwash.....Peoria
Treasurer, Robert Johnston.....Pontiac
Secretary, P. H. Tracy, Dept. of Food Technology, University of Illinois, Urbana, Ill.
Corresponding Secretary, J. W. Hayes.....Princeton
Sergeant-at-Arms, Paul Lierman.....Champaign

CHICAGO DAIRY TECHNOLOGY SOCIETY
President, Adolph Brunner.....Chicago
Vice-President, Paul Pertz.....Chicago
Treasurer, Robert W. Atkins.....Gary, Ind.
Secretary, P. H. Tracy, University of Illinois, Urbana
Sergeant-at-Arms, Dave Oatman.....Chicago

CONNECTICUT ASSOCIATION OF DAIRY AND FOOD SANITARIANS
President, H. D. Neumann.....New Haven
Vice-President, L. R. Dowd.....Storrs

Secretary, H. C. Goslee, Department of Farms and Markets, State Office Building, Hartford
Treasurer, C. W. Chaffee, State Office Building, Hartford

INDIANAPOLIS DAIRY TECHNOLOGY CLUB
President, O. Reed.....Indianapolis
Vice-President, E. Alsop.....Indianapolis
Secretary, F. J. Babel, Purdue University
Assistant Secretary, W. K. Moseley.....West Lafayette
Treasurer, W. Howe.....Indianapolis

MASSACHUSETTS MILK INSPECTORS' ASSOCIATION
President, Edward Williams.....West Springfield
Vice-President, Joseph J. Donovan.....Brookline
Secretary-Treasurer, John J. Curtin, 57 Germain Ave., Quincy 69, Mass.
Publicity Officer, John J. Manning, Milk Control Board, 140 Washington St., Boston.

METROPOLITAN DAIRY TECHNOLOGY SOCIETY
President, Paul Corash.....New York, N. Y.
Vice-President, G. L. Franke.....Farmingdale, N. Y.
Secretary-Treasurer, F. H. Pletcher, L. I. Agri. & Tech. Institute, Farmingdale, N. Y.
Sergeant-at-Arms, Alexander Brown, Long Island City, N. Y.

PHILADELPHIA DAIRY TECHNOLOGY SOCIETY
President, William Fusselbaugh.....Philadelphia
First Vice-President, Dr. J. L. Barnhart, Philadelphia
Second Vice-President, Dr. R. E. Hittle, Philadelphia
Secretary-Treasurer, W. S. Holmes, Dairy Council, Inc., 234 S. 22nd St., Philadelphia
Assistant Secretary-Treasurer, Donald Hayes, Turner & Wescott, Inc., 1327 N. Marston St., Philadelphia

California Association of Dairy and Milk Sanitarians

Mr. Clarence Plath, 58, City Milk Inspector for Los Angeles in the Orange County Area, died March 20 from a heart attack. Plath had been a member of the Los Angeles staff for three years. He leaves his widow, Irene.

Mr. Earl Smith, Milk Inspector for Imperial County Health Department, has been promoted to be in charge of the General Sanitation Program for that department.

Mr. Joseph Galatro, Milk Inspector for Merced County and formerly with the Oakland Health Department, has been appointed manager of the Mission Creamery at Los Banos.

Regional meetings are held in California of city, county and state milk control officials several times a year as indicated. Such a meeting has been called for May 17 in Merced to include representatives of San Joaquin Valley departments and Los Angeles, San Francisco, and Oakland personnel operating in the area. Principal discussion will center around pipe line milking machine installations, sediment testing of milk from holding tanks, and a revision of the dairy farm report card.

Market milk transportation from dairy to plant is rapidly being converted to tank trucks in California. Most of the distributors in the metropolitan areas are 100% equipped for tank truck deliveries or in the process of becoming so, and the trend is extending steadily to outlying territories.

The Annual Bureau of Dairy Service Refresher Course was recently concluded. A dramatized program consisting of dialogues of actual dairy and plant inspections dealing with the various phases of the work were written and presented by staff members. The dialogues contained intentional errors of statement, policy, and conduct. The presentation of the dialogues was followed by a staff analysis for the purpose of bringing out the objectionable and worthy items and incidents. Altogether, 38 dialogues were presented during the week. The dramatized form of program was tried experimentally with the thought that action vitalizes a subject, which seems to be substantiated by the fact that more people prefer seeing the movie to reading the book on any subject. The results of

the dramatized form of program exceeded expectations and a keen sustained interest in subject matter was maintained through the last number. The complete refresher course material is being compiled in a single volume for continued study by the staff.

A committee of the California Association of Dairy and Milk Sanitarians on pasteurization met in Sacramento, February 8, 1951, to consider a final draft of the proposed amendments to our pasteurization regulations. These proposals include many of the existing provisions on pasteurization, and the amendments are intended to bring them more in line with the United States Public Health Service requirements. A series of sectional meetings with inspectors and dairy industry members are being held throughout the state during the month of May for final study and approval of the recommendations.

M. E. McDONALD

Connecticut Association of Dairy and Food Sanitarians

The Connecticut Association of Dairy and Food Sanitarians met January 25 at the Hotel Barnum in Bridgeport, with approximately 135 persons in attendance. The program included a sound film for food handlers, "Safe Service", and addresses on tank truck pick-up of milk, New York's experience with milk dispensing machines, and methods of controlling and preventing insect and rodent contamination.

The annual meeting of the Connecticut Association of Dairy and Food Sanitarians was held May 9 at the Hotel Garde in Hartford. Papers presented included: "Egg-nog Drinks"; "Penicillin and Aureomycin Residues in Milk and Their Effect on Cheese Making"; "New Things in the Dairy Industry"; "Civil Defense in the Dairy Industry"; and a report on legislation passed and pending.

CORRECTION

The name of Mr. Harry Sharer should be added to the list of members of the Committee on Applied Laboratory Methods, this Journal, January-February, 1951, page 6.

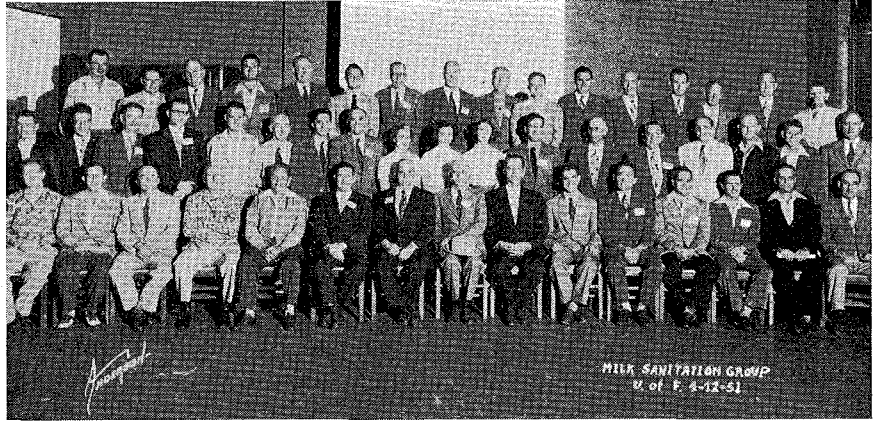

Florida Association of Milk Sanitarians

The seventh annual conference of the Florida Association of Milk Sanitarians met at the University of Florida in Gainesville April 11-13, 1951. A very excellent program was presented which was attended by approximately 75 milk sanitarians and other interested persons from all parts of the state.

Several well-known out of state speakers presented good talks. Mr. C. F. Weinreich, Head of Research Department, Cherry-Burrell Corporation, Chicago, presented talks on HTST pasteurizer and cleaning permanent milk pipe lines. Mr. Bill Bryant of Johnson & Johnson Co., Montgomery, Mich., presented a talk on sanitary milk production and also showed his self-made color movies of the Dade County Milk Program which has gained national popularity because of the progressive ideas portrayed. Mr. W. E. Botwright, from Rohm & Haas Co., Philadelphia, talked on quaternaries and Mr. A. C. Gustafson from De Laval Co., New York, talked on combine milkers.

Several Association members cooperated in presenting talks, without which the program would not have been the success that it was. Mr. S. D. Williams talked on tank trucks and Mr. Ben Northrup led a panel discussion of highlights of the 1950 International meeting, which included talks by A. G. Shaw on interstate milk shipments, S. T. Chalker, Jr. on whipped cream dispensers, W. R. Thompson on glass pipe lines, and L. T. Smith on bulk dispensers.

Staff members of the Department of Dairy Science of the University who presented papers included Dr. R. B. Becker, Dr. S. P. Marshall,

Prof. W. A. Krienke and Dr. H. H. Wilkowske. Their talks were based upon research studies conducted at the Florida Agricultural Experiment Station and included information on mastitis control, feeding practices, constituents in milk, antibiotics in dairy products and penicillin effects on plate counts.

The Florida Dairy Industry Association sponsored a friendly get-together and entertainment at a banquet held at the new student service center on the campus.

H. H. WILKOWSKE
Secretary-Treasurer

Iowa Association of Milk Sanitarians

The Iowa Association of Milk Sanitarians held their annual meeting at Ames on March 21st, just preceding the dairy short course at Iowa State College. Approximately 55 sanitarians and members attended the Association meeting. The topics discussed were on brucellosis, rabies, farm water supplies and sewage disposal. A film on water pollution was also shown. The chief topic of discussion was on the merits of the proposed state legislation for voluntary Grade A milk. This bill was passed and was signed by the governor on April 25th.

R. A. BELKNAP
Secretary-Treasurer

Michigan Association of Sanitarians

The annual meeting of the Michigan Association of Sanitarians was held April 11 at Michigan State College in conjunction with the Annual Milk and Food School and officers were elected for the coming year.

Missouri Association of Milk and Food Sanitarians

The Missouri Association of Milk and Food Sanitarians held their annual meeting at Columbia, Missouri, on April 23-25. The program was planned so as to have general meetings on the first and last day, but separate food and milk sections on the day between. The time schedule for the sectional meetings was followed closely to facilitate movement from one to the other according to particular interests. The device of attendance door prizes was used to get meetings started promptly.

Papers were presented as follows: "Germ Warfare Defense"; "Grocery Store Sanitation"; "Milk Parlor Plans"; "Milkers—Set-ups and Use"; "General Bacteriology of Milk"; "Ring Test for Brucellosis in Milk and Cream"; "Activity Test—as Applied to Grade A Milk"; "Milk Sanitation Program"; "Swab Test as a Basis for Degradation"; "Floor Care in Food Establishments"; "Communicable Diseases Transmitted by Food"; "Slaughter

Plant Sanitation"; "23% to '?' in 9 Months"; "Bakery Sanitation"; "Quats"; "The ADA Program—What It Is and How It Works"; "Standardization of Laboratories"; "Circus, Carnival and Fair Sanitation."

Virginia Association of Milk Sanitarians

The annual meeting of the Virginia Association of Milk Sanitarians, at which officers were elected for the coming year, was held on March 22-23 at Natural Bridge, Virginia. The subjects of papers presented were: "Public Relations"; "Training Personnel"; "Federal Specifications for Fresh Whole Milk and Cream"; "Quality of Milk Required by Armed Services"; "Significance and Control of Coliform Bacteria in Pasteurized Milk"; "Insulating Glass—Studies on Its Use in Milk Houses and Dairy Barns"; "The Use of Paper Containers in the Milk Industry"; "New Parlor

Milker and the Care and Cleaning of Milkers."

Massachusetts Milk Inspectors' Association

The spring meeting of the Massachusetts Milk Inspectors' Association was held May 2 at Hotel Kenmore in Boston. Papers presented included: "Dairy Equipment—Present and Future"; "Milk Dispensing Devices—Sanitation and Legal Aspects"; "The Scientific Story of Paints—Their Use in Food Processing Plants."

Metropolitan Dairy Technology Society

The April meeting of the Metropolitan Dairy Technology Society was held at the Stonewall Inn, New York City, on April 17. Mr. H. B. Robinson presented a paper on "The Milk Sanitation Program of the U. S. Public Health Service and Its Application to Federal Contracts."

Ring Test for Brucellosis

(Continued from page 110)

OBSERVATIONS

Our experience has shown that the ring test has been about 40 percent accurate when comparing it with the blood serum reactions on lactating cows in clean or lightly infected herds. In herds, negative to the blood test, the ring test does not have as much practical value, because false positive reactions do show up. Calf-hood vaccinated lactating animals sometimes interfere with the ring test results because, we are told, successful vaccination may result in the appearance of agglutinins in the milk, thus giving false positive ring test results. A small number of animals reacting to the official blood test have been overlooked by using the ring test.

The age of the milk seems to be an influencing factor on the ring results. Reacting milk at the end of three or four days, appears to have a more pronounced reaction than when it was fresh.

CONCLUSIONS

Sanitation is still one of the important factors in a brucellosis con-

trol program. Adequate veterinary service and good herd management are extremely important. Vaccination without sanitation has been very unsatisfactory in many herds infected with brucellosis. Until the spread of the infection has been stopped, there is no hope of eradicating brucellosis entirely.

The ring test can serve as an adjunct to the blood serum agglutination test, but it will probably never replace it. It can lend itself to differentiating presumably clean and infected cows or herds where there are no blood testing programs. It seems apparent that we need further knowledge as to the comparative value of the ring test and blood tests in indicating udder infection and the shedding of *Brucella* in the milk.

From the herd disease control standpoint, it is very desirable to locate newly infected cows as early as possible in order to reduce the spread of the disease within the herd. This is where the ring test can serve as an adjunct to the blood test, locating possible active infections.

6. It does not serve as a true index so far as udder infection is concerned.

Some of the values of the ring test as we observed them are:

1. It is a screening procedure which can be directed to some high titer blood reactors in infected herds.
2. It is more sensitive in detecting agglutinins in milk than the milk whey agglutination method.
3. It can be a rapid, inexpensive method of locating infected herds; it also provides an easy way and lends itself to frequent checking of clean herds.
4. Indications are that in numerous cases the ring test results will locate animals from a month to a year before their blood titers go up.
5. A vast amount of laboratory work and veterinarians time can be eliminated if the ring test of mixed or composite herd milk is used. One ring test from a group of 25-50 cows will detect any animal giving or shedding the antibodies or agglutinins in their milk. If negative results are obtained, no bleeding is indicated, but a positive reaction would indicate the necessity of a blood test on the herd, or possibly indicate a ring test on each animal in the herd to determine the offending animal.
6. The ring test could be effectively used in a brucellosis eradication program on an area basis.

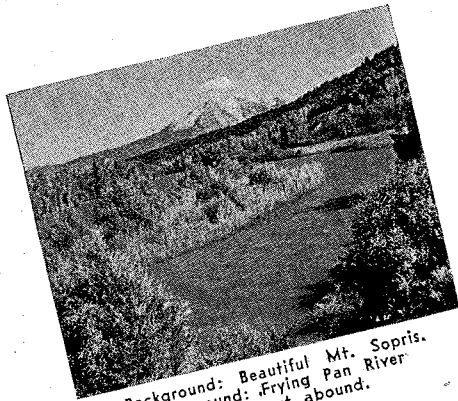

Background: Beautiful Mt. Sopris.
 Foreground: Frying Pan River
 where trout abound.

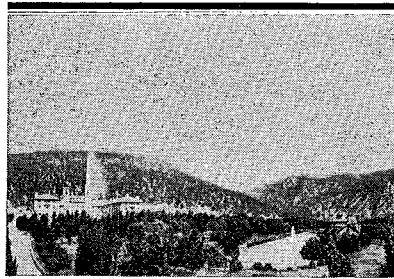

Hotel Colorado and grounds.



Hotel Colorado patio swimming pool, warm
 fresh water. No charge to guests and
 convention delegates.



ATTENDANCE
 O. J. Weimann, Chief
 Food Sanitarian, Colo-
 rado State Health De-
 partment, Denver

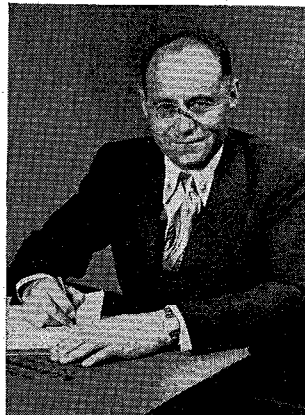

*Chairman, Local Arrangements
 Committee*
HAROLD J. BARNUM
 Chief, Milk Section, Department
 of Health and Charity, West 6th
 Avenue and Cherokee St., Denver



ENTERTAINMENT
 Howard M. Weindel,
 Training Officer, Rocky
 Mountain Training Cen-
 ter, Denver

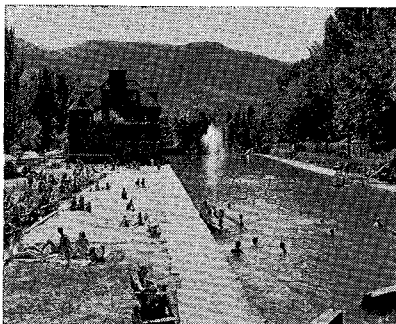

Largest outdoor warm mineral water swimming
 pool in the world. Length: 650 ft.,
 Temperature 72-75°. Swimming
 and bathing daily.



**LADIES
 ENTERTAINMENT**
 Mrs. Nevin Kilpatrick, Di-
 rector, Denver Dairy
 Council, Denver



Sure-footed western ponies for both the
 novice and expert on mountain trails are
 available, under the friendly super-
 vision of an experienced guide.

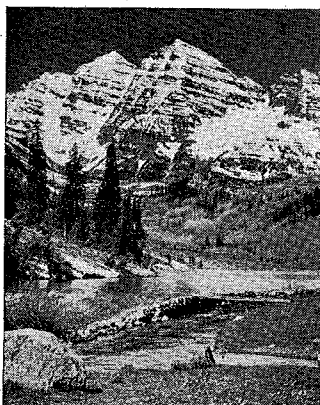

Maroon-Bells (14,126 ft.) and Lower
 Maroon Lake — Alpine gem of
 the Glenwood region.



RECEPTION
 J. E. Dolan, Milk Sani-
 tarian, Colorado State
 Health Dept., Denver



FINANCE
 Ward K. Holm, Secretary,
 Colorado Dairy Products
 Association, Denver

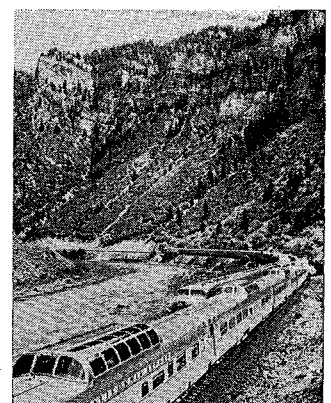

The Vista Dome California Zephyr
 in beautiful Glenwood
 Canyon.

**Thirty-eighth Annual Meeting
 Glenwood Springs, Col., Sept. 26-29, 1951**

News Items

Cincinnati Dairy Technology Society Shows Rapid Growth with 120 Members Now Enrolled

The Cincinnati area technologists met at the Hotel Alms recently (April 12) for an organization dinner meeting. Dr. Thomas D. Harman, dairy technological specialist and faculty member of the Ohio State University's College of Agriculture, Columbus, was guest speaker. He discussed "The Current Interest in Concentrated Milk".

Permanent organization of the Cincinnati dairy technologists will be effected by election of officers and trustees shortly. Arthur Kasserle, Cincinnati plant manager for Swift & Company, was designated chairman of the nominating committee.

William Funke, President The Hyde Park Dairy, Cincinnati, was chosen chairman of a committee to prepare constitution and by laws.

An administrative committee chosen to guide the activities of the society pending election of permanent officers includes charter founding members; George Coors, Coors Brothers Dairy; Luther Mindling, Gillespie Milk Products; Edward Weber, Weber Dairy Company; John Brockschmidt, The Kroger Company; Ross J. Winning, G. P. Gundlach & Company, dairy industry consultants and Norbert Woebkenberg, The H. Woebkenberg Valley View Dairies, Reading, Ohio, who is serving as temporary chairman.

The next monthly dinner meeting of the society was scheduled for May 10.

Indiana Association of Milk and Food Sanitarians

The Indiana Association of Milk and Food Sanitarians has been organized, and officers elected, at a meeting held March 14. Officers are: President—James H. McCoy, Indianapolis; President-elect—George White, Evansville; First Vice-President—Russell Cunningham, LaPorte; Second Vice-President—John M. Schlegel, Indianapolis; Secretary-Treasurer—J. C. Schneider, Indianapolis; Auditors—Clarence Taylor, Indianapolis, and J. W. Ballard, New Albany.

Manitoba Institute for Sanitary Inspectors

An Institute for Sanitary Inspectors was held March 13-16 at the University of Manitoba, Fort Garry. Papers included on the program were: "Cattle Infections and Disease Conditions of Interest to Milk Supply Supervisors"; "Milk Production Problems as Experienced by a Pasteurization Plant"; "Market Milk Processing Methods"; "Market Milk Handling and Processing Equipment"; "Receiving, Grading and Sampling Market Milk"; "Significance of Results of Coliform Test"; "Personal Public Relations"; "Manufacture of Carbonated Beverages"; "Water Problems in Bottling Plants"; "Locker Plant Sanitation and Housekeeping"; "Some Principles Regarding the Freezing Method of Food Preservation"; "Quality and Characteristics of Meat"; "Good Meat Handling Techniques"; "Spoilage in Meat and Meat Products." There were also demonstrations of milking machine operation, producing clean milk of low bacterial count, and cleaning dairy equipment; and films on refrigeration and meat handling.

CALENDAR

- | | |
|--------------------|---|
| Aug. 21-25 | 15th National Convention, National Association of Sanitarians, Miami Beach, Fla. |
| Sept. 3-7 | Diamond Jubilee Meeting, American Chemical Society, New York City. |
| Sept. 6-7 | Oklahoma Association of Milk and Food Sanitarians, Norman, Okla. |
| Sept. 26-29 | 38th Annual Convention, INTERNATIONAL ASSOCIATION OF MILK AND FOOD SANITARIANS, INC., Glenwood Springs, Colo. |
| Oct. 17-18 | 30th Annual Conference for Vermont Dairy Plant Operators and Milk Distributors, Burlington, Vt. |
| Oct. 29-
Nov. 2 | Western Branch with A.P.-H.A., Civic Auditorium, San Francisco, Cal. |

Washington Association of Milk Sanitarians

The Washington Association of Milk Sanitarians was organized as an affiliate of the IAMFS at the 20th annual State College of Washington Institute of Dairying. Officers were elected as follows: President—Leslie E. Jenne, Olympia; Vice-President—David W. Jones, Everett; Secretary-Treasurer—L. O. Tucker, Seattle.

Supreme Court Invalidates Milk Ordinance

(Continued from page 102)

In reaching its decision, the Supreme Court found that Madison, "even in the exercise of its unquestioned power to protect the health and safety of its people," cannot, by its ordinance, discriminate against interstate milk shipments "if reasonable nondiscriminatory alternatives, adequate to conserve legitimate local interests, are available."

The Court pointed to the existence of two such alternatives. They are:

1. The city may rely on its own officials for inspection of distant milk sources and charge the cost of the inspection to importing producers; or,
2. The city may adopt the milk ordinance and code recommended by the Public Health Service, which, the Court said, "imposes no geographical limitation on location of milk sources and processing plants but excludes from the municipality not produced and pasteurized conformably to standards as high as those enforced by the receiving city."

The Madison ordinance was brought before the Wisconsin Supreme Court approximately two years ago, when its constitutional validity was attacked by the Dean Company, which had been denied a license to sell its products within the city solely because its pasteurization plants were more than five miles out of the city. The Court noted that the Dean Company at that time purchased and gathered milk from approximately 950 farms in northern Illinois and southern Wisconsin, none of which was within 25 miles of Madison. None of its pasteurization plants was nearer than 65 miles from the city.

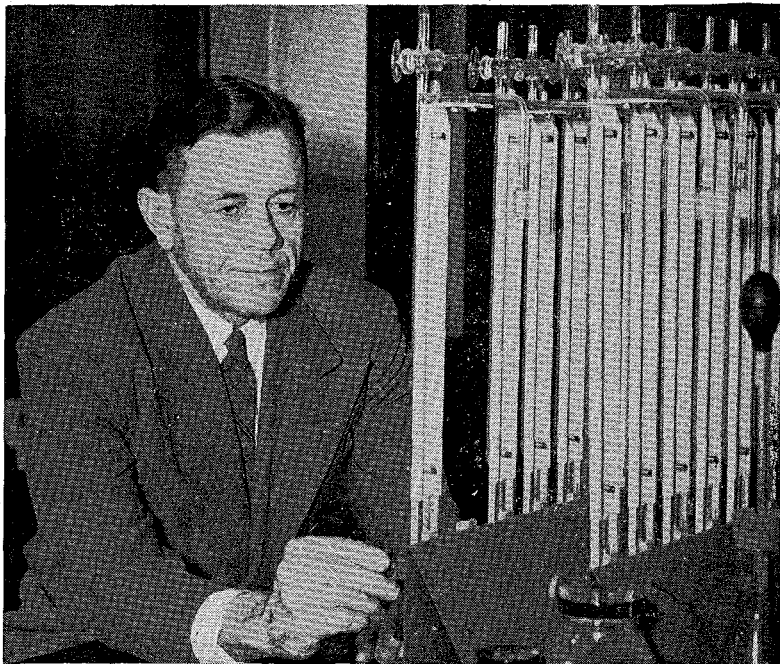

Dr. Thomas Leroy McMeekin was born at Monticello, South Carolina, on May 8, 1900. He attended public schools in this state and graduated from Clemson College with a B.S. in chemistry in 1921. The following year he obtained an M.S. from Tulane University. After teaching for one year at the Medical College of South Carolina he entered the graduate school of the University of Chicago, from which he received a Ph.D. in biochemistry in 1925.

Dr. McMeekin was an assistant professor of biochemistry at Emory University for the years 1925-27. He then entered industrial work for a time, being engaged in the production of insulin for E. R. Squibb and Son in 1927-28. The next 12 years, 1928-1940, Dr. McMeekin was a research associate in the Department of Physical Chemistry, Harvard Medical School. In 1940, he became senior chemist in the Protein Division of the Eastern Regional Research Laboratory, in charge of the Production and Purification Section. Since 1947 he has been Head of the Protein Division. In this position he has supervised the work of 20 odd members of the division upon various phases of the chemistry and utilization of milk proteins. Despite the administrative responsibility in the latter two positions, Dr. McMeekin has been an active participant in the research of his associates and has continued to perform experimental work which is marked by his fundamental and thorough approach to any problem.

McMeekin Wins Borden Award

The Borden Award has the announced purposes of the recognition and encouragement of outstanding research achievements in the chemistry of milk; the award is available for work done either in Canada or the United States.

After three years as a teacher at Emory University and two years in the field of Insulin production, our medalist spent the period from 1928 through 1940 as a research associate at Harvard University Medical School. During this latter period his researches were devoted to fundamentals in the physical chemistry of amino acids, peptides and related substances. Since 1940 in his work at the Eastern Regional Research Laboratory this year's recipient has

made outstanding contributions particularly to the fundamentals of the chemistry of milk proteins. Certain surface active agents were shown to be effective precipitants for lactalbumin and lactoglobulin. A brilliant study was made on the hydration and other factors that are fundamental in an understanding of the chemistry of crystalline betalactoglobulin. The medalist and his associates have made fundamental contributions in studies of the separation of alpha and beta casein and have also isolated gamma casein. Significant increase in the proportion of alpha casein has been shown toward the end of the lactation period. Other studies have dealt with electrophoretic properties and with the

manufacture of acid precipitated casein. Conditions were developed for the successful extrusion of casein filaments to prepare a bristle fibre.

The medalist's work on the various phases of the chemistry of milk proteins is regarded as a major achievement that is unmatched either in this country or abroad in the last ten years.

It is an honor to present Dr. Thomas L. McMeekin of the Eastern Regional Research Laboratory, U. S. Department of Agriculture, the 1951 recipient of the Borden Award in the Chemistry of Milk to Mr. W. A. Wentworth, Secretary of the Borden Company Foundation, the donor of this prize of \$1,000 and a gold medal.

Announcement of Regular Corps Examination for Sanitary Engineers

United States Public Health Service

Competitive examinations for the appointment of officers as Sanitary Engineers in the Regular Corps of the United States Public Health Service will be held on August 6, 7, and 8, 1951. Examinations will be held at a number of points throughout the United States, located as centrally as possible in relation to the homes of the candidates. Applications must be received no later than July 9, 1951.

The Regular Corps is a commissioned officer corps composed of members of various medical, technical, and scientific professions.

Appointments will be made in the grades of Assistant Sanitary Engineer (equivalent to Navy rank of Lieutenant, j.g.) and Senior Assistant Sanitary Engineer (equivalent to Lieutenant) . . . Duty assignments are made with consideration of the officer's ability and experience and in accordance with a plan for career development. Such assignments include

general sanitary engineering, water pollution control, industrial hygiene, insect and rodent control, milk and food sanitation, and environmental health research activities.

REQUIREMENTS

Assistant Sanitary Engineer: At least seven years of professional training and experience subsequent to high school graduation, including the receipt of a bachelor's degree in engineering (preferably in civil, sanitary, or chemical engineering) from a university of recognized standing. At least two of the seven years must have been qualifying professional training or experience in the field of public health or in an acceptable related field.

Senior Assistant Sanitary Engineer: At least 10 years of professional training and experience subsequent to high school graduation, including the receipt

of a bachelor's degree in engineering (preferably in civil, sanitary, or chemical engineering) from a university of recognized standing. At least four of the ten years must have been qualifying professional training or experience in the field of public health in the employment of an official or non-official health agency or in an activity directly related to the field of public health.

Applicants who will meet these qualifications within nine months of the date of the written examination (that is, no later than May 6, 1952) may take the examination, but may not be appointed until they fulfill the requirements. The examination will last approximately three days and will include an oral interview; physical examination; and comprehensive objective tests covering water and sewage, stream pollution including industrial wastes, insect and

(Continued on next page)

William B. Palmer, East Orange, New Jersey, Managing Editor of this Journal and former president of this Association, died suddenly, on May 25, of a heart attack. For several years he has been suffering from an increasing complexity of ailments. Without doubt, the increased pressure attendant upon the reorganization of the Journal contributed to this outcome.



Mr. Palmer has been executive officer of the Milk Inspection Association of the Oranges (five municipalities) and Maplewood, New Jersey, since the association was formed

thirty-five years ago. Previous to that he was Assistant Oranges health officer. He became a licensed health officer in 1914. In 1922 and 1923 he was president of the New Jersey Health Officers' Association; in 1928 and 1929, president of Central Atlantic States Food and Drug Officials Association; in 1931 and 1932, president of the International Association of Milk and Food Sanitarians; in 1945, president of the New Jersey Health and Sanitary Association.

In 1931, he was chairman of food and nutrition section of the American Public Health Association. He started and at the time of his death was managing editor of the *Journal of Milk and Food Technology*, official publication of the INTERNA-

TIONAL ASSOCIATION OF MILK AND FOOD SANITARIANS.

Mr. Palmer was a pioneer in milk inspection and was largely responsible for the success of the organization he headed. The latter was formed in 1915 as a step to eliminate diseases traced to contaminated milk supplies. It was a revolutionary step at the time, not only in requiring close supervision of milk supplies but also in joining together five municipalities in a joint agency. This work was started back in the old days. He suffered the difficulties of the pioneer in milk control work. However, his constancy, idealism, practicality, and knowledge, enhanced by an attractive personality, gradually won the dairymen. Now they are his friends and supporters.

Announcement of USPHS Regular Corps Examination

(Continued from preceding page)

rodent control, garbage and refuse, milk and food sanitation, air and industrial hygiene, public health administration and related social sciences. The eligibility of candidates for admission to the examination is subject to the approval of an examining board, and the decision of the board regarding the acceptability of training and experience is final.

Physical Requirements: Candidates must be found physically qualified as a result of an examination performed at a Public Health Service facility.

Gross pay is identical to that of officers of equivalent rank in the Army and Navy. Entrance pay for the Assistant grade with dependents is \$4,486.56 per

annum; for Senior Assistant with dependents, \$5,346.00. These figures include subsistence and rental allowance. Officers on active duty are not eligible to receive disability compensation from the Veterans Administration.

Promotions: Provisions are made for promotion at regular intervals up to and including the grade of Senior Sanitary Engineer (Commander) and for promotion by selection to the grade of Sanitary Engineer Director (Captain).

Retirement pay after 30 years of service or at age 64 is three-fourths of annual basic pay at the time of retirement. Minimum disability retirement pay is ordinarily one-half of annual basic pay at the time of retirement.

Additional benefits include periodic pay increases (time served as an active or inactive member of the armed forces is credited), 30 days annual leave, sick leave, full medical care, and the usual privileges extended to officers of the military forces.

Application forms may be obtained by writing to the Surgeon General, Public Health Service, Federal Security Agency, Washington 25, D. C., Attention: Division of Commissioned Officers, DESK "A".

Applications must be received in the Washington Office on or before July 9, 1951. Those received after this date cannot be accepted.

NEW MEMBERS

Cameron S. Adams, State Dept of Agriculture, Olympia, Wash.
John R. Albrecht, 440 N 6½, Terre Haute, Ind.
Arthur A. Anderson, Zumbroto, Minn.
George Andrews, 1626 Smith Tower, Seattle, Wash.
Howard A. Andrews, 515½ Dayton, Muskogee, Okla.
Walter Ash, Kalamazoo Health Dept., Kalamazoo, Mich.
L. R. Bacon, Wyandotte Chem. Corp., Wyandotte, Mich.
Howard L. Baker, R-1, Cameron, Wis.
O. Ballarin, Nestles Products, Caixa Postal 760, Rio de Janeiro, Brazil
Floyd Bear, RFD 2, Coffeyville, Kan.
Dudley N. Beall, Benton-Franklin Dist. Health Dept., Box 489, Pasco, Wash.
Prof. G. H. Beck, Dairy Husbandry Dept., Kansas St. College, Manhattan, Kan.
W. A. Beck, c/o J. C. Olson Jr., Dairy Division, Univ. of Minnesota, St. Paul 1, Minn.

Paul E. Begin, Dairy School of Province of Quebec, St. Hyacinth, Quebec, Canada
T. S. Bellair, Rex Bldg., 402 Swanston St., Melbourne, C.L., Aust.
Ted J. Bliss, Land O Lakes Creameries, Pine City, Minn.
Clarence L. Bradley, 6 Roberts St., Fargo, N. Dakota
Melvin G. Brandanger, Melvin G., 2613 3rd Ave. S., Minneapolis, Minn.
Joe Braun, 240 3rd St., Reedsburg, Wis.
Howard L. Bright, 3250 Fairfax Rd., Kansas City, Kan.
A. J. Brinkman, City Hall, St. Cloud, Minn.
J. R. Brunner, Michigan State College, East Lansing, Mich.
L. F. Bugbee, 125 Washington St., Wausau, Wis.
Lee R. Burton, Steffens Dairy, Ada, Oklahoma
B. A. Campbell, 413 N. W 7th, Abilene, Kan.
E. L. Carr, The Borden Co., Perry, Okla.
James V. Cawley, 855 Avenue of Americas, New York, N. Y.

C. B. Chappelle, Bryan Co. Health Dept., Durant, Okla.
C. B. Cohen, 401 Chatauqua St., Norman, Okla.
William V. Cook, 321 E. Sunnyside Ave., Libertyville, Ill.
Wilfred Barnes Cooper, Box #124, Sequim, Wash.
William A. Cordes, National Dairy Prod. Corp., 230 Park Avenue, New York 17, N. Y.
Willard J. Corbett, 1126 Kilburn, Rockford, Ill.
Harold S. Coss, 15725 Evergreen, E. Detroit, Mich.
Coughlin, John, 15725 Evergreen, E. Detroit, Mich.
James Covington, 429 McLemore St., Brownville, Tenn.
Pearl Cowden, 431 Charles St., Reedsburg, Wisc.
Frank O. Cox, Caddo Co. Health Dept., Anadarko, Okla.
Ray H. Cromley, 760 Campbell Ave., Detroit, Mich.
Walter A. Culley, 240 N. 7th, Salina, Kan.

- Earl Culver, Spring Green, Wis.
Robert Dalton, Minn. Dept. of Health, Univ. of Minnesota, Minneapolis, Minn.
C. A. Day, Bennett, Creamery Co., Ottowa, Kan.
Cpl. Edgar A. Day, 641127, Co. "A," 1st Bn., 6th Reg., 2nd Marine Div., Camp LeJeune, N. C.
Lee DePriest, 702 6th, Baldwin, Kan.
Simon S. Dixon, 1018 S 4th St., Duluth, Minn.
W. R. Docker, 925 Keeler Ave., Beloit, Wis.
M. J. Dotter, State of Ohio Health Dept., Columbus 15, Ohio
Lawrence C. Dormuth, Penn. Salt Mfg. Co., 1000 Widener Bldg., Philadelphia, Pa.
Dean Duke, Marian Co. Health Dept. Marian, Kan.
Guy Duncan, 700 E. Central, Wichita, Kan.
A. J. Duris, 1626 Smith Tower, Seattle, Wash.
Marvin W. Edmunds, 3250 Fairfax Rd., Kansas City, Kan.
Calvin J. Emerson, V J Apt. 7, Pratt, Kan.
Frank H. Engle, 112 W. Laurel, Independence, Kan.
C. H. Epperley, Clover Creamery, Roanoke, Va.
Dan A. Evans, 2646 N 21st Pl., Kansas City, Kansas
David H. Evans, State Health Dept., Austin, Texas
Roy Fairbanks, 15 Fox St., Aurora, Ill.
C. R. Farnham, 375 Henry St., Burlington, Wis.
Prescott S. Farrar, New Hampshire State Health Dept., Henniker, N. H.
John R. Ferris, R. R. No. 1, Wappingers Falls, N. Y.
James A. Fikes, McClain Co. Health Dept., Purcell, Okla.
Paul Fillio, 715 North 81st St., Seattle 3, Wash.
Richard Fiskin, City Hall, Great Bend, Kan.
Alfred J. Fletcher, Denton, Maryland
H. J. Fournelle, P. O. Box 960, Anchorage, Alaska
Harvey Fram, National Dairy Res. Labs., Oakdale, N. Y.
Andrew B. Freeman, 216 N. Connecticut Ave., Atlantic City, N. J.
Archie B. Freeman, U.S.P.H.S. Office Bldg., 112 Federal, San Francisco, Cal.
Dwane L. Gallup, Waconia, Minn.
Ralph T. Gardiner, Gardiner Dairy, Garden City, Kan.
Edward A. Garfield, Norwalk, Wis.
David Garrick, 79 Collier St., Barrie, Ont., Canada
Solomon N. Goldstein, 59 E. Madison, Chicago 3, Ill.
Henry L. Goodnough, 28½ Main St., Delhi, N. Y.
J. B. Gotcher, City Health Dept., Blackwell, Okla.
Scottie Gound, Marian Co. Health Dept., Marian, Kan.
E. A. Graber, Ohio Dept. of Health, Columbus, Ohio
C. T. Grams, Tonganoxie, Kan.
Ernest Hahn, Kraft Foods Co., 734 Grove St., Hutchison, Minn.
C. K. Hansen, c/o J. C. Olson Jr., Dairy Div. Univ. of Minnesota, St. Paul 1, Minn.
Russell E. Hansen, R. R. #1, Albert Lee, Minn.
Ernie Harms, Thayer, Kan.
Jay Harris, 535 Indiana St., Lawrence, Kan.
H. A. Healy, Dairy Products Lab., 2276 Como Ave., St. Paul, Minn.
Robert Henderson, 835 Chestnut Rd., East Lansing, Mich.
Merwin Henley, Coon Valley, Wis.
Frank Hereford, 908 Federal Bldg., Detroit, Mich.
Orville Hoch, Hock Dairy, RFD, Emporia, Kan.
Ben A. Hoffman, Land O Lakes Creameries, Benson, Minn.
Ernest J. Homuth, Hebron, Ill.
J. W. Hosey, Okfuskee Co. Health Dept., Okemah, Okla.
Richard Hoyt, 405 W. Washington, Urbana, Ill.
James B. Hume, 1310 No. 82nd, Seattle 3, Wash.
Herman Ichuerg, RFD 5, Coffeyville, Kan.
H. W. Janzen, Box 391, Vancouver, Wash.
Leslie E. Jenne, State Dept. of Agriculture, Olympia, Wash.
C. R. Jensen, c/o J. C. Olson, Jr., Dairy Division, Univ. of Minnesota, St. Paul 1, Minn.
J. M. Jensen, 3747 Lilac St., East Lansing, Mich.
Cecil O. Johnson, 3937 Pilgrim St., Seattle, Wash.
David Jones, 431 Berkshire Dr., Everett, Wash.
Harry Johnson, 416 W. South St., Bluffton, Ind.
Ed. Kaeder, Maple Island Farm, Stillwater, Minn.
C. L. Kaufman, Morgan Co. Health Dept., Decatur, Alabama
Louis R. Kaufman, MSC USN B.O.O., A52, Room 130, Naval Base, Norfolk, Va.
Arthur E. Kaye, 318 E. Locust St., Bloomington, Ill.
Fred Kellow, Gladwin, Mich.
Willard C. Kerncamp, 3402 Portland Ave., Minneapolis, Minn. (7)
Saced M. Kheshegi, Microbiology Div., Nat. Dairy Res. Labs., Oakdale, N. Y.
C. H. P. Killick, 143 Legislative Bldg., Winnipeg, Manitoba, Canada
E. G. Kingry, 132 N. Walnut, Wichita, Kan.
Vincent V. Kiser, 817 So. Williams, Bluffton, Ind.
Nobel C. Kline, 1010 W. Chestnut, Dodge City, Kan.
Paul H. Knoll, R #1, Williamsburg, Mich.
Elwood A. Knudson, West Concord Butter & Cheese Assn., West Concord, Minn.
Grayden Kraemer, RFD Marrayville, Kan.
Joseph B. Krug, 419 Coal St., Pottsville, Penna.
Harold Kruse, 2847 Ninth Ave., Rock Island, Ill.
Raymond A. Kubista, 2031 North Ave., Middleton, Wis.
Carl Kunish, Lyon Co. Health Dept., Emporia, Kan.
E. W. Larson, 423 Frederick St., Clay Ctr., Kansas
Marion Laug, Michigan State College, East Lansing, Mich.
H. S. Leedy, 7419 Walnut, Kansas City, Missouri
Jack B. Lee, Payne Co. Health Dept., Stillwater, Okla.
Walter K. Lloyd, Kraft Foods Co., Box 1163, Chicago 90, Ill.
Frank W. Logan, 2818 West Eaton, Seattle 99, Wash.
Chester Long, City Dairy, Manhattan, Kan.
Edward S. Love, Jr., 749 Third St., Huntington 1, W. Va.
A. Bender Luce, N-724 Park St., Colfax, Wash.
A. E. Lundstrom, 635 N. Parkwood Lane, Wichita, Kansas
Leo Maki, 908 Federal Bldg., Detroit, Mich.
E. F. Malter, 811 Hiawatha Ave., Hiawatha, Kan.
Dr. Samuel Mares, de la Pena, Gume-cindo Esquier #65 Col. Parque Asturias, Mexico, D. F.
Earl H. Martin, Midland Co. Health Dept., Midland, Mich.
R. B. Maxey, Kansas State College, Manhattan, Kan.
L. E. McCarty, Tonganoxie, Kansas
W. R. McLean, USPHS Fidelity Bldg., 2200, Kansas City, Mo.
Glenn E. Merrill, 1540 Fairmont, Wichita, Kan.
John W. Merriott, Central Kansas Coop. Creamery, Hillsboro, Kan.
E. F. Meyer, DVM, Grand Rapids Health Dept., Grand Rapids, Mich.
Emil Mikolajcik, Dept. of Dairy Technology, Ohio State Univ., Columbus 10, Ohio
Howard P. Milleville, Food Processing, 737 N. Michigan Ave., Chicago 11, Ill.
Myrl Millsap, 3250 Fairfax Rd., Kansas City, Kan.
O. D. Moore, 201 Norman Bldg., Dallas, Texas
Capt. Wm. C. Moughon, U.S. Air Force, 375th Med. Group, Air Force Base, Shepherd, Texas
Ray Muchow, R 2, Loganville, Wis.
Earl Myers, 113 Kickapoo, Hiawatha, Kan.
Nathan Nagle, Carbondale Branch Lab., Carbondale, Ill.
Elmer E. Nelson, Linstrom Creamery, Lindstrom, Minn.
Stanley Neilson, Clinton Pure Butter Co., Clinton, Iowa
Fred A. Nichols, 69 W. Washington St., Room 200, Chicago 2, Ill.
Donald J. Niederpruen, 530 Berkshire Ave., Buffalo, N. Y.
C. R. O'Connor, 425 S. Garden St., Bellingham, Wash.
Philip Olmsted, Saginaw Health Dept., Saginaw, Mich.
John C. Ostrom, 300 Public Safety Bldg., Seattle, Wash.
Yoshiatsu Ozaki, Welfare Ministry, Tokyo, Japan
William A. Parks, 211 S. Brady, Urbana, Ill.
W. D. Paschal, Lawrence Co. Health Dept., Lawrence, Kan.
B. F. Pelton, Box 354, Spring Green, Wis.
H. A. Peterson, Chisago City Coop. Cry., Chisago City, Minn.
Lloyd S. Peterson, Box 341, Cashton, Wis.
Ward K. Peterson, 2929 University Ave., Site 32, Madison 5, Wis.
Edw. J. Pfeifer, 537 E. Sumner St., Hartford, Wis.
M. L. Raines, State Health Dept., Austin, Texas
Harold L. Ramos, Route No. 1, Box 27, Lafayette, La.
D. L. Rasmussen, Reinbecke, Iowa

(Continued on next page)

Industrial Notes

New Diversey Bulletin

The Diversey Corporation, Chicago, has just published Diversey Technical Bulletin #201 on Control of Thermoduric Bacteria in Dairy Products, second offering in the series known as the Diversey Technical Library of Dairy Plant Sanitation.

Copies of Diversey Technical Bulletin #201 may be obtained by writing to: Dairy Department, The Diversey Corporation, 1820 Roscoe Street, Chicago 13, Illinois.

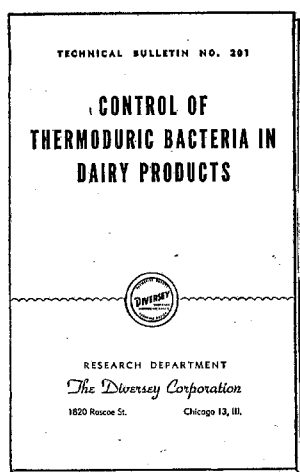

Oakite Booklet on Cleaning

Oakite has released a discussion of how steam-detergent cleaning saves time and work and helps cut costs in connection with industrial maintenance operations, presented in an illustrated folder available from Oakite Products, Inc., manufacturers of industrial cleaning and related materials.

The folder defines steam-detergent cleaning as the simultaneous application of *three* different actions: (1) the *physical* action of steam pressure and hot water working their way through successive layers of grease and dirt; (2) the *dissolving* action of heat on oils, greases and other deposits; and (3) the *chemical* action of the detergent in penetrating, wetting and emulsifying surface deposits.

The folder also supplies detailed specifications of the types of steam-cleaning equipment available from this manufacturer, and offers helpful data on the preparation of efficient working solutions for use with this equipment. Readers desiring free copies of this folder may obtain them by addressing Oakite Products, Inc., 38C Thames St., New York 6, N. Y.

Index to Advertisers

Corning Glass Works.....	II
Johnson & Johnson.....	III
Cherry-Burrell Corp.....	IV
Crown Cork & Seal Co.....	VI
Schwartz Mfg. Co.....	VII
Sealright Co.....	VIII
American Can Co.....	IX
Creamery Package Mfg. Co.....	X
American Seal-Kap Corp.....	XI
Oakite Products, Inc.....	XI
Klenzade Products, Inc.....	XI, XIV
Sterwin Chemicals, Inc.....	XII
Penn Salt.....	XIII
Diversey Corp.....	XIV
The Borden Co.....	XV
Aluminum Co. of America....	XVI
Smith-Lee Co.....	XVII
Waukesha Foundry Co.....	XVII
Bowey's, Inc.:.....	XVIII
Difco Laboratories.....	Back Cover

New Members

(Continued from preceding page)

- Orville Rasmussen, 808 Harding Ave., St. Paul, Minn.
 Harry M. Read, 723 34th Ave., Seattle 22, Wash.
 Wayne N. Renneke, North Branch, Minn.
 Vance Reynolds, Muskogee Co. Health Dept., Muskogee, Okla.
 Raleigh J. Richard, Acadia Parish Health Unit, Crowley, La.
 William I. Richards, 704 11 Ave. W., Calgary, Alta., Canada
 Claude Rievriere, 3157 Ontario St., Montreal, Quebec, Canada
 Ronald Robb, RFD 5, Lawrence, Kan.
 C. M. Robilliard, Jr., 3750 NE 5th St., Minneapolis, Ill.
 C. E. Rosenberg, c/o J. C. Olson Jr., Dairy Div. Univ. of Minnesota, St. Paul 1, Minn.
 B. J. Rosenthal, Wyandotte Chem. Corp., Northwestern Bank Bldg., Minneapolis, Minn.
 Dee Sammons, Fairmont Foods Co., 431 W. 14, Concordia, Kan.
 Nicholas J. Santora, 711 D So. Poplar St., Ottawa, Kan.
 Eugene M. Sautters, Rm. 109, City Hall, Bayard St., New Brunswick, N. J.
 Leonard G. Schock, 1725 Jackson St., LaCrosse, Wis.
 Leland Schultz, 909½ Summer St., Eau Claire, Wis.
 Lyaal Searing, 300 Public Safety Bldg., Seattle 4, Wash.
- Bernhard H. Seefeldt, Fox's Guernsey Dairy, Waukesha, Wis.
 Ernest Segesser, 456 S. Winter St., Adrian, Mich.
 Dr. J. C. Selke, 30 Whitewood Rd., Toronto 12, Ontario, Canada
 Ray Sellers, 1007 W 6th, Lawrence, Kan.
 W. K. Sharpe, Dept. of Health & Welfare, Charlottetown, P.E.I. Can.
 Glen A. Shaw, 220 N 4th St., St. Louis 4, Mo.
 Philip Shirley, Route #1, Box 68, Eaton Rapids, Mich.
 Frank Skapyak, Turtle Lake, Wis.
 Vic. Soderstrom, 120 E. 6th St., Junction City, Kan.
 Rolland Spaun, Chemlab, Michigan Dept. of Agriculture, Lansing, Mich.
 Lloyd B. Spivak, Prairie Farms of Western Ill., Mount Sterling, Ill.
 Lt. Col. Mervyn B. Starnes, 1819 W. Pershing Rd., Chicago 9, Ill.
 Benjamin J. Stenson, Health Dept., Kingfisher, Okla.
 Alfred D. Stocking, East Stanwood, Wash.
 David R. Strobel, Dairy Branch PMA, USDA, Washington, D. C.
 M. L. Strommer, P. O. Box 116, Aberdeen, Wash.
 Vernon D. Sturm, 6 & High St., Baldwin, Kan.
- H. N. Stuverude, 1236 6th Ave. S. E., Rochester, Minn.
 Earl Teal, Ontario, Wis.
 John F. Tienken, Jr., Box 535, Cameron, W. Va.
 Dave T. Tyler, 314 W. Sherman Ave., Ft. Atkinson, Wis.
 Dennis Urban, University of Wisconsin, Apt. 123, Badger, Wis.
 Albert C. Waite, Wilson, N. Y.
 F. T. Walker, City Hall, Salina, Kan.
 Elmer Weibel, Beatrice Foods Co., Oskaloosa, Kan.
 Howard M. Weindel, State Board of Health, Topeka, Kan.
 Robert Weir, 1816 Polk, Great Bend, Kan.
 J. Harper Wetherington, New Bern, N. C.
 Miles Wheeler, R. 2, Blair, Wis.
 Arthur Wiedemer, RR 2, Box 220, Covington, Ohio
 H. V. Wilkerson, 700 W. Central, Wichita, Kan.
 J. L. Wings, c/o J. J. C. Olson, Jr., Dairy Div., Univ. of Minnesota, St. Paul 1, Minn.
 Harry S. Workman, New Cumberland, W. Va.
 Earl O. Wright, Dept. of Dairy Industry, Univ. of Wisconsin, Madison 6, Wis.
 Thomas F. Wyatt, Health Dept., Claremore, Okla.
 George Wynn, R.R. #1, Danville, Ill.
 Walter Zobrist, 2414 East 60th St., Seattle 5, Wash.

THE B·K[®]

PATRON RELATIONS PLAN

really works for me...



Fieldman Palmer (right) helping Dairyman Dunning simplify his milking sanitation routine.

... writes Fieldman Hugh Palmer

The fieldman's job is a difficult one, and the B-K PR Plan is a sincere effort to ease the fieldman's task. By stressing the importance of strict sanitation it adds its voice to that of the fieldman, lending outside authority to the fieldman's endeavors.

Here are some of the materials it offers:

"TIMELY TIPS"—a monthly educational leaflet for producers, explaining quality milk production, seasonal and regional farm problems, as well as interesting items in dairying history.

VISUAL AIDS—Film strips, motion pictures, and assistance in planning meetings.

All this material is offered *free* in the

interests of the dairy industry by the makers of B-K cleaners and sanitizers.

Fieldmen and plant owners everywhere tell about the effectiveness of this B-K Patron Relations Plan in improving milk quality.

Health officers and sanitarians who would like to receive the Plan regularly are invited to write: Department 35, Pennsylvania Salt Manufacturing Company, Philadelphia 7, Pa.



dairy chemicals

PROGRESSIVE CHEMISTRY FOR OVER A CENTURY

It's New!
It's Improved!
It's Outstanding!

NEW IMPROVED

DIVERSEY DILAC
Amazingly Superior Milkstone Remover!

Now... "DOUBLE-ACTION" DILAC Gives You Complete Milkstone Removal At Low Cost with Assured Safety for Equipment Surfaces!

SEE THE UNMATCHED PERFORMANCE OF NEW IMPROVED DIVERSEY DILAC IN YOUR OWN PLANT... ON YOUR OWN EQUIPMENT! CALL YOUR DIVERSEY D-MAN TODAY...OR PHONE, WRITE OR WIRE US DIRECT FOR IMMEDIATE ACTION!

COMPLETE
SANITATION
FOR YOUR PLANT!



Diversey offers a complete line of specialized sanitation chemicals for the modern food plant. Backed by over 25 years of research, development and in-the-field experience, puts Diversey, its products and services in a position to better serve you and meet all your sanitation requirements. Call your Diversey D-Man when you need help.

THE DIVERSEY CORPORATION

1820 Roscoe Street, Chicago 13, Illinois
In Canada: THE DIVERSEY CORPORATION (Canada) LTD.
Lakeshore Road, Port Credit, Ontario

KLENZADE SERVICES

TO THE

dairy industry



First

to pioneer the now famous Alternate System of Cleaning. A Klenzade innovation scientifically alternating organic acid and alkaline detergents.

First

to offer complete Plant Sanitation Surveys and set up Cleaning Programs raising sanitation standards and reducing labor and material costs.

First

to offer simple, economical field and plant Test Kits for testing solution strengths of detergents, bactericides, pH, water hardness and causticity.

First

to offer the Chem-O-Shot... the only positive displacement feeder on the market... powered by motion of the washer itself. Used on bottle washers and can washers.

First

to offer Fog Sanitizing Units for applying sanitizing solutions to tank trucks, storage tanks, milk cans and vats.

First

to offer Mineralight Ultra-Violet Light which detects milkstone by fluorescence. A simple but efficient sanitation aid.

Other Klenzade Services

Other services to the dairy industries include: Laboratory Testing; Water Analysis; Boiler Water Treatment; Water Chlorination; Detergent Brick Feeding; Vitamin Feeding and Educational Programs. Every well informed plant manager should know all about these Klenzade Services.



Write for Complete Information

KLENZADE PRODUCTS, Inc.

Offices in Principal Cities

BELOIT

WISCONSIN

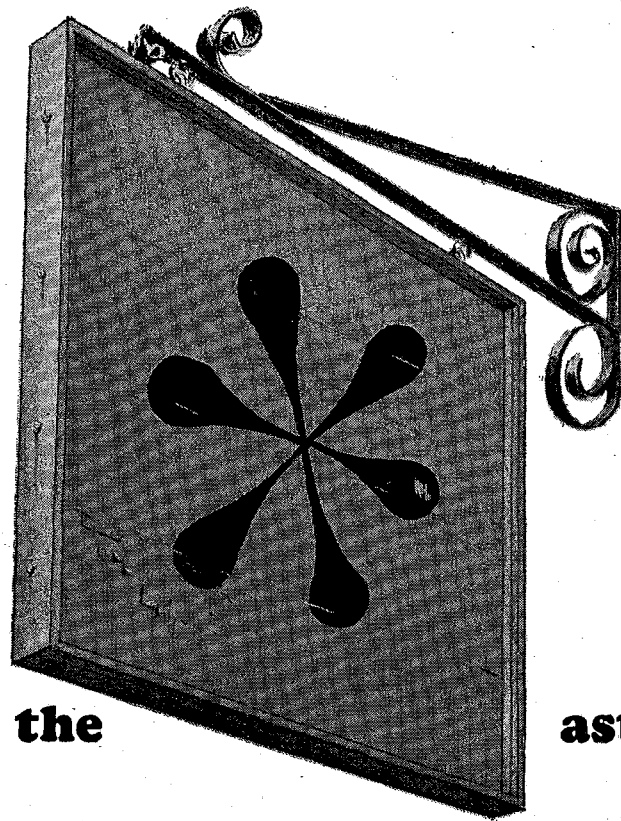

Stop at the sign of the

asterisk

Ever hear of the old roadside inn called "The Asterisk"? It is said to have been a popular place in its day, famous for cheerful hospitality, safe lodging, and above all good food . . . This was perhaps the first association on record of an asterisk with the term "good food"—but it was certainly not the last.

Over the past 94 years many an asterisk in the medical and nutritional literature has referred to Borden food products or to work done in the Borden laboratories. It was in 1857 that Gail Borden helped establish the foundation for today's specialized knowledge of infant feeding by inventing a process for concentrating and preserving milk. A committee of the New York City Academy of Medicine praised the purity of his product in comparison with raw milk from the unsanitary cowsheds of that early day.* Following in Gail Borden's footsteps, Borden has since dotted the literature with

asterisks referring to important developments stemming from its research. To cite only a few instances—collaboration with public health authorities in establishing pasteurization standards,** perfecting of process for freezing human milk,*** work done on the development of riboflavin,**** numerous improvements in infant and adult foods.*****

Today you are more likely than ever to encounter an asterisk referring to Borden in the literature. Borden products now range from milk and milk products, ice cream, cheeses, Instant Coffee and many other foods for daily family use, to the special prescription foods, Bremil, Infose, Biolac, Dryco, Gerilac and Mull-Soy. We have come a long way since the 1850's but our goal is still what it was in the beginning: better nutrition for the American people, in sickness and in health.

Leslie's Weekly* May 22, 1858. *Public Health Bulletin*, No. 147, published by U. S. Public Health Service, Feb. 1925. ****J. Pediat.* April 1933. ****Silver medal awarded to Borden research workers for original investigations of pure lactoflavin (riboflavin) at 87th Annual Session of AMA, Kansas City, May 1936. *****For a recent reference to Borden's New Improved Biolac, see: *J. Pediat.* Jan. 1951; for Gerilac: *Am. J. Surg.* April 1949; for Mull-Soy: *J. Allergy* Jan. 1947.

Manufacturers and distributors of BORDEN'S Beta Lactose; BIOLAC infant food; DRYCO infant food; KLIM powdered whole milk; MERRELL-SOULE Powdered Skimmed Milks; MULL-SOY hypoallergenic food; BORDEN'S Evaporated Milk; STARLAC non-fat dry milk; Instant Coffee, Fresh Milk, Ice Cream & Cheese.

The Borden company

350 Madison Avenue, New York 17, N. Y.



**perfect protection for
nature's most perfect food**

A L U M I N U M C O M P A N Y O F A M E R I C A

1742 Gulf Building, Pittsburgh 19, Penn.

**Milk Twice Capped
is Twice Protected by
Smith-Lee "CELLOPHANE" Hoods**

- Fresh, sparkling "Cellophane" Hoods protect the inner seal of safety . . . safeguard the vital finger-grip area.
- They're Dust-proof . . . Weather-proof . . . TAMPER-PROOF!
- Nationally approved by health authorities!

Designed for
**BETTER HEALTH...
BETTER LIVING...by**

**CAP
HEADQUARTERS**
SMITH-LEE CO., Inc. ONEIDA, N.Y.



No Paint Needed...

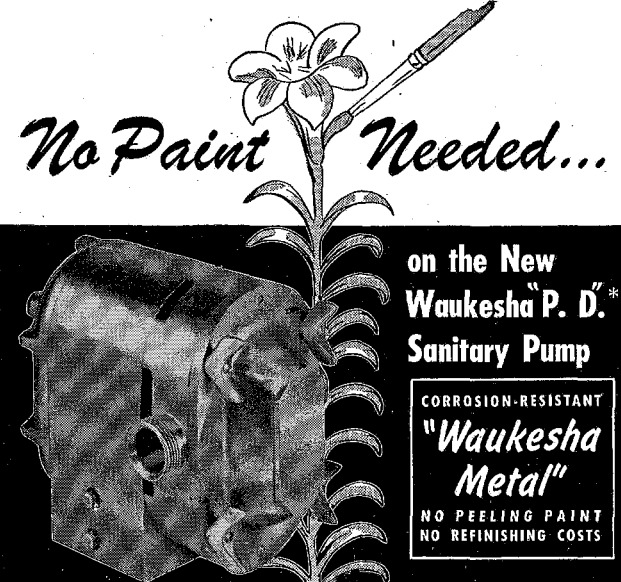

**on the New
Waukesha "P. D."
Sanitary Pump**

CORROSION-RESISTANT
**"Waukesha
Metal"**
NO PEELING PAINT
NO REFINISHING COSTS

- New One-Piece O-RING SANITARY SEALS eliminate TEN former parts — Save cleanup time.
- Positive Displacement, Twin-Blade Impellers provide Non-Agitating, Non-Aerating Pumping.
- Heavy Duty Ball Bearings for longer service.
- New Adjustable Ball Feet with high clearance for easy floor sanitation.
- New Time Savings in Sanitation — no cracks or crevices inside or outside.
- Available in V-Belt, GEARHEAD, Reeves, or U. S. Variable Speed models, all with or without the Vented Cover.

WAUKESHA "P.D." Pumps, made completely of polished corrosion-resistant "Waukesha Metal," retain their sparkling sanitary finish with a minimum of cleaning and attention. You'll have no paint peeling, chipping or cracking, no tarnish or rust, no expensive maintenance or refinishing costs. You get "lifetime" modern beauty and efficiency.

Sanitary "Waukesha Metal" construction is only one of many advantages of the new Waukesha "P.D." Sanitary Pump. Check ALL the features. They add up to **GREATER PUMP VALUE** for you.

**P. D. — Positive Displacement — Slow Speed*

Modernize your pumping NOW! Write today for the complete story on the new Waukesha Sanitary "P.D." Pump with its many extra-value features.

WAUKESHA FOUNDRY CO.
WAUKESHA, WISCONSIN

Waukesha **100%
SANITARY
PUMPS**

Dependable Product of a Responsible Manufacturer



Thanks! Inspector...

**...FOR THE JOB YOU HAVE
DONE...AND FOR YOUR
CONTINUING EFFORTS TO
KEEP QUALITY FIRST!**

In our business, sanitation is a most vital aspect of quality. While we as manufacturers undertake the necessary research and inspection to keep DARI-RICH at the top in quality . . . it is your important function to *maintain* such standards in the field.

And these efforts over the years have greatly increased the quality of dairy products, including the nationally-famous DARI-RICH Chocolate Flavored Milk and Drink. For your help, we thank you—and endorse your constant vigilance to protect the health of our nation.





for Microbiological Assay

of

VITAMINS and AMINO ACIDS

Bacto dehydrated media containing all the necessary nutriments and growth factors for the microbiological assay of vitamins and amino acids are now available from Difco. These basal media require only the addition of graduated amounts of the substance under assay to obtain linear growth of the test organism for construction of the standard curve. The vitamin or amino acid content of the material under assay is determined by adding appropriate concentrations of the test substance to the basal medium and comparing the growth response obtained with the standard.

BACTO-FOLIC ACID ASSAY MEDIUM

BACTO-RIBOFLAVIN ASSAY MEDIUM

BACTO-NIACIN ASSAY MEDIUM

BACTO-THIAMIN ASSAY MEDIUM

BACTO-PANTOTHENATE ASSAY MEDIUM

BACTO-TRYPTOPHANE ASSAY MEDIUM

BACTO-PYRIDOXINE ASSAY MEDIUM

BACTO-VITAMIN B₁₂ ASSAY MEDIUM

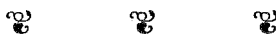

The method employed in carrying stock cultures of the test organisms and preparing the inoculum for microbiological assay is important. The following media have been developed especially for carrying stock cultures and for preparation of the inoculum.

BACTO-MICRO ASSAY CULTURE AGAR

BACTO-MICRO INOCULUM BROTH

BACTO-NEUROSPORA CULTURE AGAR



BACTO-VITAMIN FREE CASAMINO ACIDS, dehydrated, is an acid hydrolysate of vitamin free casein prepared especially for laboratories investigating microbiological assay of vitamins.

Descriptive literature is available upon request.

Specify "DIFCO"

The Trade Name of the Pioneers in the Research and Development
of Bacto-Peptide and Dehydrated Culture Media

DIFCO LABORATORIES

DETROIT 1, MICHIGAN